



<b>Application Note to the Field</b>	<b>Gear Pump Models H1, 31 &amp; 41</b>
<b>Application Note Number:</b> 0105-1	<b>Date:</b> May 1, 2001; Revised Sept. 2022

Liquiflo Models H1, 31 and 41 are low-flow external gear pumps with a maximum capacity of ~ 0.5 GPM. These are some of our best sellers and are reliable pumps when specified and applied correctly. Occasionally, there have been a few questions about them.

Models H1/31/41 through H5F/35F/45 have the same lateral and radial clearances (i.e., about the same “slip”) and so as the pump gets smaller, slip becomes a higher *percentage* of total displacement (see diagram on next page). For this reason, there have sometimes been difficulties with the H1/31/41 pumps running on fluids with very low viscosities (less than 10 cP) at moderate to high differential pressures (greater than 50 psi / 3.4 bar).

To prevent potential performance issues due to increased slip, it is highly suggested to use elastomeric O-rings, such as Viton, in lieu of the standard O-ring material (virgin Teflon), to seal the housings for models H1/31/41. Viton “squishes” more easily than Teflon, as the latter is not an elastomer, and in a semi-captive O-ring groove, Teflon can prevent the housings from seating that tiny bit extra that can mean a performance difference.

In order to ensure that the pumps will perform per the published curves or performance software, the H1/31/41 pumps should be used on fluids with at least 10 cP viscosity. This will achieve the most stable performance. For fluids under 10 cP, the H3/33/43 models can have more success. Note that an existing H1/31/41 pump can be easily converted to a H3/33/43 by changing the gears and wear plates. (A repair kit or individual parts can be used to make the conversion.) If it is absolutely necessary to use the H1/31/41 pumps on fluids with less than 10 cP viscosity, they should not be specified for over 0.25 GPM at 50 psi (3.4 bar).

Carbon bearings and wear plates should be considered first, if compatible. Carbon is inexpensive, hard, relatively self-lubricating, and forgiving. A bearing grade (BG) PEEK idler gear is also a good idea if this material can be used in the application. BG PEEK is very strong, smooth, and inert to many fluids. Kynar gears should be considered for high-purity applications or as an alternative to PEEK. If these materials are not compatible with the application, consider double metal gears (either Alloy-C vs. Alloy-C or Alloy-C vs. 316 SS). While this is not perfect, with such small gears it is usually not a problem at over 10 cP. Teflon and Carbon are not available for gears in this pump size due to the very small teeth and the likelihood of breaking them at start-up. Ryton, while a very good choice for many fluids in the larger pumps, can experience brittle fractures in such a small gear.

Although the bearing loading is minimal for the H1/31/41 pumps, due to forces imparted (Force = Pressure x Area, where there is very little area on the gear teeth of this pump), hard-coated shafts are highly suggested to prevent wear and significantly increase pump lifetimes. Coated shafts should be specified whenever Teflon or SiC bearings are used. This is because the glass that is used to reinforce the PTFE, or the extreme hardness of SiC, can be abrasive to a plain metal shaft.

## Liquiflo Application Note to the Field: Gear Pump Models H1, 31 & 41

For mag-drive pumps, the MCU magnetic coupling (which has replaced the MCS and MCA) can transmit up to 75 in-lbs of torque at room temperature. This is adequate for all applications involving models H1/31 and H3/33, since the maximum torque for these pumps is based on the torque limit of the gear keys (23 in-lbs). The MCN magnet (20 in-lbs) is sufficient for most applications of models 41/43 up to 250°F; the MCR magnet (30 in-lbs) is used for high-temperature applications over 250°F and/or high-viscosity applications.

**Diagram:** Slip of Models H1/31/41 vs. Models H5F/35F/45

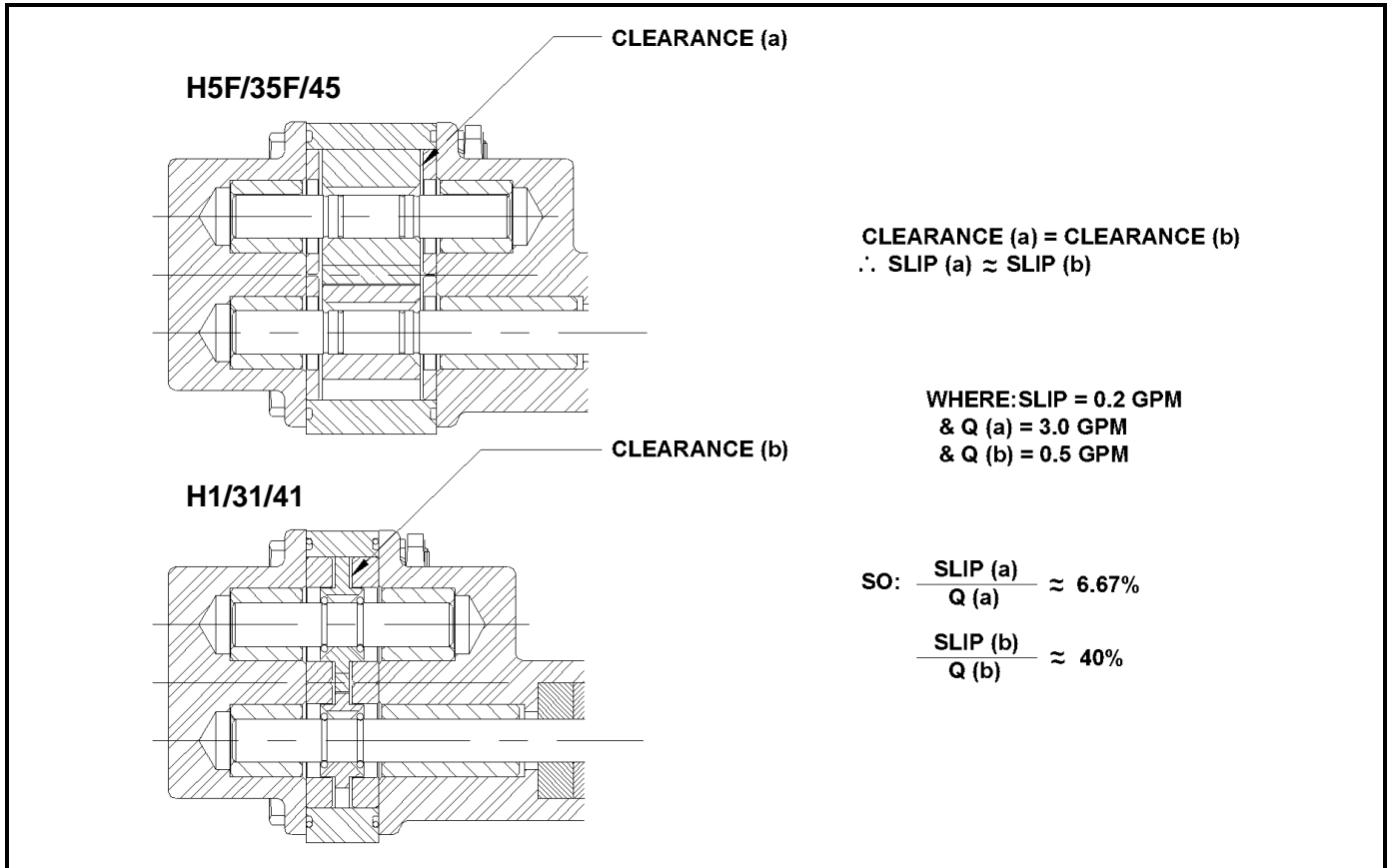

The following chart gives the standard available materials for Models H1, 31 and 41:

HOUSINGS	GEARS	SHAFTS	BEARINGS	WEAR PLATES
316 SS Alloy-C Titanium <sup>1</sup>	316 SS Alloy-C Titanium <sup>1</sup> BG PEEK <sup>2</sup> Ryton <sup>3</sup> Kynar <sup>4</sup>	Uncoated 316 SS or Alloy-C Chrome Oxide-Coated Tungsten Carbide-Coated Titanium Oxide-Coated Ti <sup>1</sup>	Carbon <sup>5</sup> SiC ( $\alpha$ grade) BG PEEK <sup>2</sup> Teflon <sup>6</sup>	Carbon <sup>5</sup> SiC ( $\alpha$ grade) BG PEEK <sup>2</sup> Teflon <sup>6</sup>

1 - Available for Model 41 only

4 - Pure PVDF; for Model H1 only

2 - 30% carbon fiber/PTFE/graphite

5 - Graphite grade

3 - PPS/25% glass/15% PTFE

6 - 25% glass-filled PTFE