

SERIES	MODEL	CONFIGURATION	SEAL TYPE
H-Series 3-Series	H1F or H3F 31F or 33F	Mag-Drive Gear Pump Long-Coupled Base-Mounted Version with RF Flanges.	Mag-Drive (Sealless)

UNITS: inches [mm]

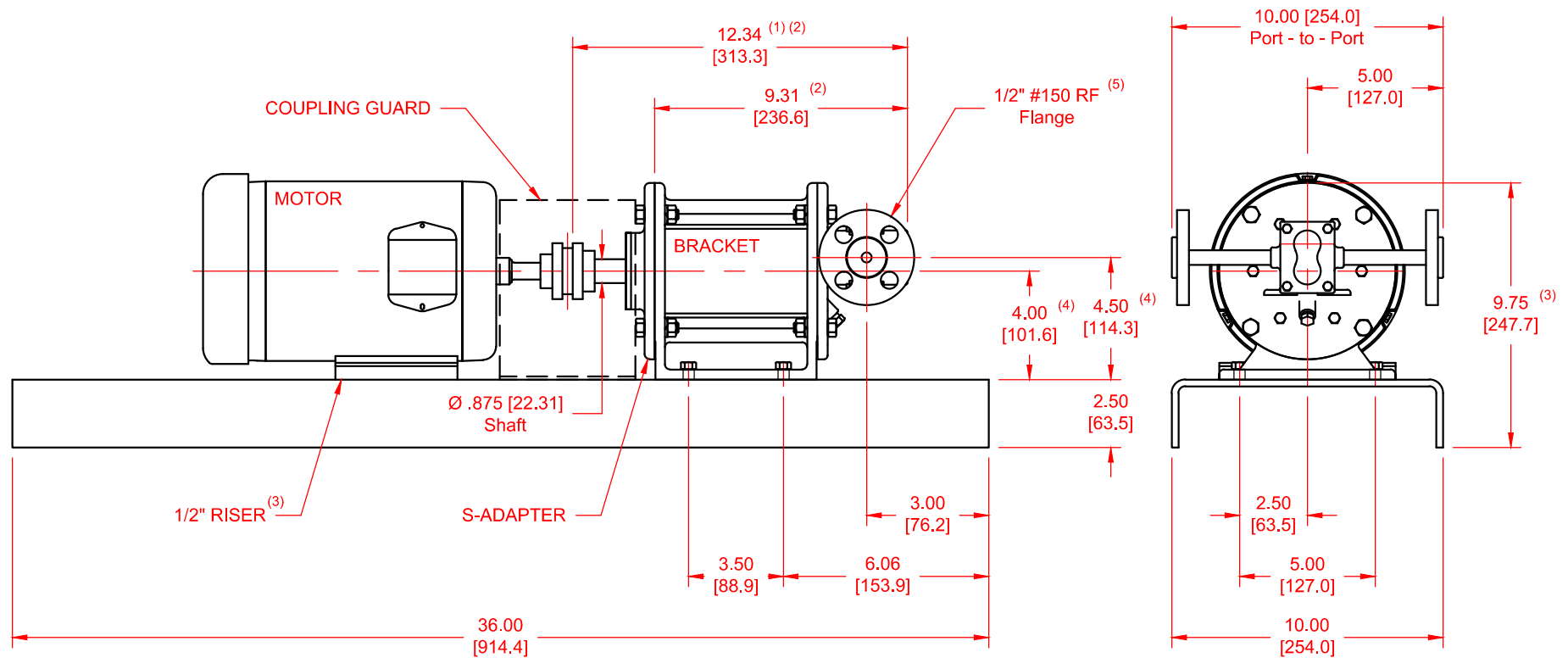

NOTES:

- 1) Dimension to end of pump shaft.
- 2) Dimension to end of pump rear housing.
- 3) Dimension to the top of Bracket.
- 4) Applies for NEMA 56, 143T & 145T Motors.
- 5) Also available with ANSI 1/2" #300 RF and DN10 PN 16 flanges.