

SERIES	MODEL	CONFIGURATION	SEAL TYPE
H-Series 3-Series	H7F, H7R or H7N 37F, 37R	Sealed Gear Pump, Long-Coupled Base-Mounted Version with NPT or BSPT Ports	Single Mechanical Seal, Double Mechanical Seal or Packing

UNITS: inches [mm]

SEAL TYPE	37R shaft Ø.500		37F shaft Ø.500	
	"A"	"B"	"A"	"B"
Single or Double Mechanical Seal	1.23 [31.2]	8.20 [208.3]	1.11 [28.2]	8.32 [211.3]
Packing	1.25 [31.8]	8.20 [208.3]	1.13 [28.7]	8.32 [211.3]
SEAL TYPE	H7R or H7N shaft Ø.625		H7F shaft Ø.625	
	"A"	"B"	"A"	"B"
Single or Double Mechanical Seal	1.23 [31.2]	8.20 [208.3]	1.11 [28.2]	8.32 [211.3]
Packing	1.25 [31.8]	8.20 [208.3]	1.13 [28.7]	8.32 [211.3]

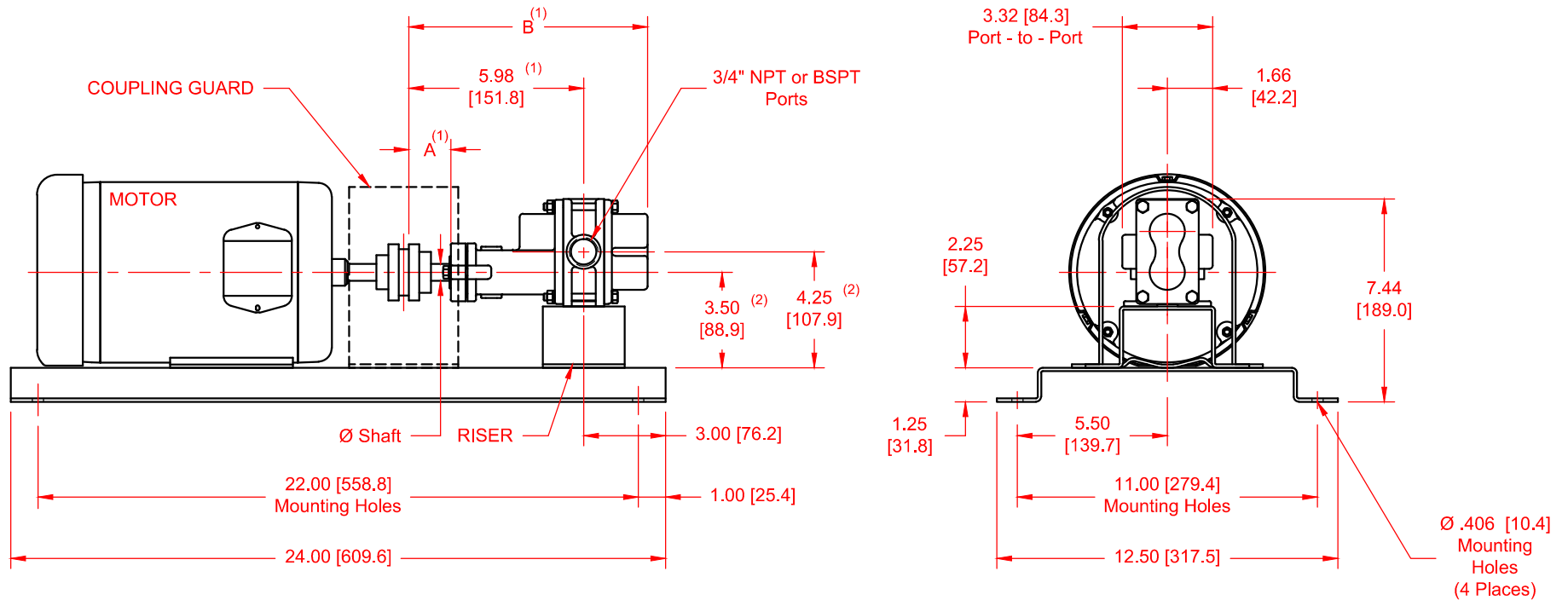

NOTES:

- 1) Dimension to end of pump shaft.
- 2) Applies for NEMA 56, 143T & 145T Motors.