

SERIES	MODEL	CONFIGURATION	SEAL TYPE
Max-Series	M4	Mag-Drive Gear Pump Close-Coupled Base-Mounted Version with RF Flanges.	Mag-Drive (Sealless)

UNITS: inches [mm]

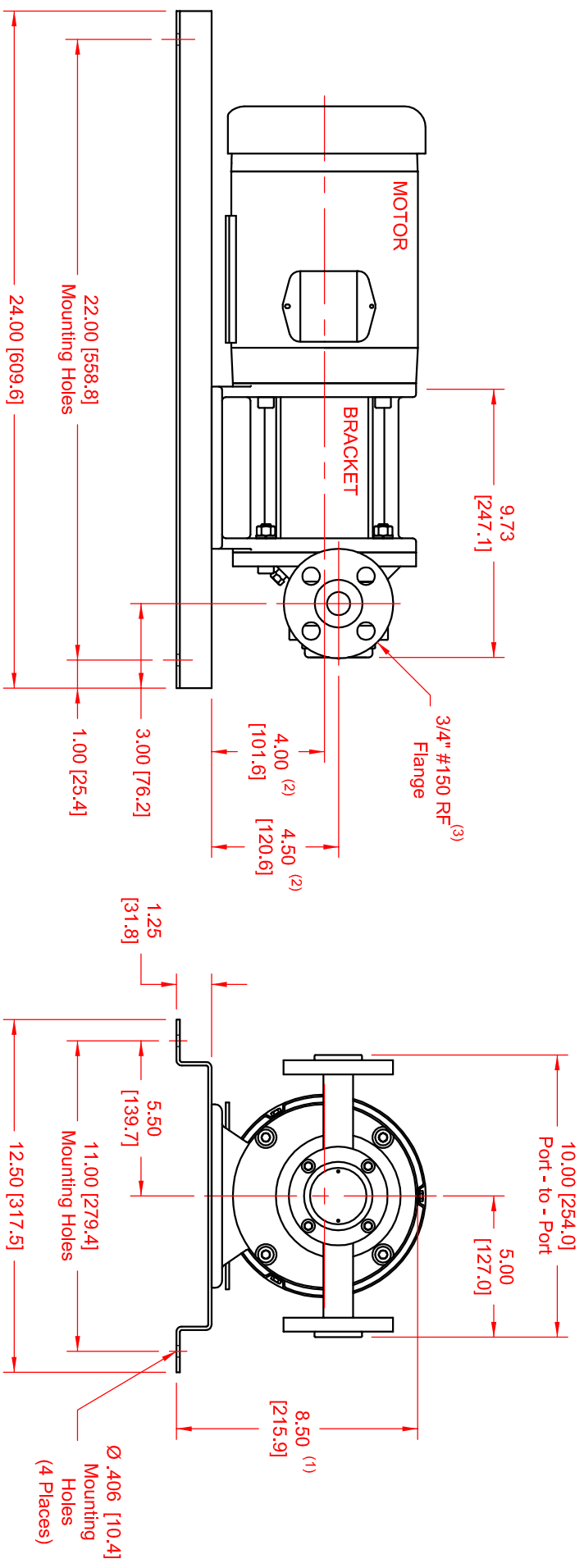

- NOTES:**
- 1) Dimension to top of Bracket.
 - 2) Applies for NEMA 56C, 143TC & 145TC Motors.
 - 3) Also available with ANSI 3/4" #300 RF and DN20 PN16 flanges.