



CONSOLIDATED BILL OF MATERIALS (BOM) FOR STANDARD H-SERIES GEAR PUMPS



**Models H12R & H12F
Sealed, Long-Coupled**



**Models H12R & H12F
Mag-Drive, Long-Coupled**



**Models H12R & H12F
Sealed, Close-Coupled**



**Models H12R & H12F
Mag-Drive, Close-Coupled**

Table of Contents

Models H12R & H12F:	SEALED-LC:	316 SS Construction 2-3
		Alloy-C Construction 4-5
	MAG-DRIVE-LC:	316 SS Construction 6-7
		Alloy-C Construction 8-9
	SEALED-CC:	316 SS Construction 10-11
		Alloy-C Construction 12-13
	MAG-DRIVE-CC:	316 SS Construction 14-15
		Alloy-C Construction 16-17
		Appendix 1: Exploded View Reference Drawings 18-21
		Appendix 2: Meaning of Abbreviated Terms 22
		Appendix 3: Additional Parts for SEALED-CC Configuration 23
		Appendix 4: Additional Parts for MAG-DRIVE-CC Configuration 24

Liquiflo Chemical Processing Pumps™	H-Series Gear Pumps BOM: SEALED, LC Models H12R & H12F
--	---

Part Description	Drwg. Item #	316 Stainless Steel Construction			
		Code	Material	H12R	H12F
Position 3 – Basic Material & Port Type (Center Housing, Alignment Pins, Coupling Key & Hardware)					
Center Housing, NPT	21	S	316 SS	3120004	3120004
Center Housing, Flanged (ANSI 150# RF)	21	L	316 SS	3120003	3120003
Center Housing, BSPT	21	X	316 SS	3120008	3120008
Pin, Housing Alignment	12	S, L, X	316 SS	3120801 (4)	3120801 (4)
Key, Mechanical Coupling (Pump Shaft)	28	S, L, X	CS	3121900	3121900
Bolt, Housing (5/16-18 x 1 HHCS)	4	S, L, X	18-8 SS	3122004 (12)	3122004 (12)
Lockwasher, Housing (5/16)	15	S, L, X	18-8 SS	3126341 (12)	3126341 (12)
Position 4 – Drive Gear					
Gear	22	1	Alloy-C	990021	990017
Gear	22	3	Teflon	990058	990061
Gear	22	6	316 SS	990020	990016
Gear	22	K	Kynar	990085	990666
Gear	22	P	PEEK	990023	990019
Key, Gear	23	1, 3, 6, K, P	316 SS	990026	990026
Position 5 – Idler Gear					
Gear	6	1	Alloy-C	990021	990017
Gear	6	3	Teflon	990058	990061
Gear	6	6	316 SS	990020	990016
Gear	6	8	Ryton	990022	990018
Gear	6	K	Kynar	990085	990666
Gear	6	P	PEEK	990023	990019
Key, Gear	24	1, 3, 6, 8, K, P	316 SS	990026	990026
Position 6 – Wear Plates					
Wear Plate, Relieved	7	3	Teflon	3120522 (4)	3120505 (4)
Wear Plate, Relieved	7	4	SiC	3120513 (4)	3120507 (4)
Wear Plate, Relieved	7	E	Carbon 60	3120524 (4)	3120504 (4)
Wear Plate, Relieved	7	P	PEEK	3120502 (8)	3120502 (4)
Position 7 – Bearings					
Bearing	3	3	Teflon	990065 (4)	990065 (4)
Bearing	3	B	SiC	990006 (4)	990006 (4)
Bearing	3	E	Carbon 60	990008 (4)	990008 (4)
Bearing	3	P	PEEK	990007 (4)	990007 (4)
Position 8 – Seal Type					
Mechanical Seal, Single Internal	11	U	316 SS/Carbon	990028	990028
Mechanical Seal, Single Internal	11	S	316 SS/Teflon	990041	990041
Mechanical Seal, Double	11	F	316 SS/Carbon	990067	990067
Mechanical Seal, Double	11	H	316 SS/Teflon	990068	990068
Seal Seat, Outer	25	U, S, F, H	SiC	990062	990062
Seal Seat, Inner	26	F, H	SiC	990063	990063
Gland Plate, SMS & DMS	17	U, S, F, H	316 SS	990013	990013
Bolt, Gland (5/16-18 x 1 HHCS)	16	U, S, F, H	18-8 SS	3122004 (2)	3122004 (2)
Lockwasher, Gland (5/16)	19	U, S, F, H	18-8 SS	3126341 (2)	3126341 (2)
Plug, 1/8 NPT	9	U, S	316 SS	362304 (3)	362304 (3)
Plug, 1/8 NPT	9	F, H	316 SS	362304 (1)	362304 (1)
Packing Ring	18	L	Teflon	990055 (5)	990055 (5)
Packing Ring	18	R	Graphoil	990056 (5)	990056 (5)
Lantern Ring	11	L, R	316 SS	990053	990053
Gland Plate, PS	17	L, R	316 SS	990057	990057
Bolt, Gland (5/16-18 x 1 HHCS)	16	L, R	18-8 SS	3122004 (2)	3122004 (2)
Grease Fitting, 1/8 NPT	25	L, R	303 SS	867201	867201
Plug, 1/8 NPT	9	L, R	316 SS	362304 (2)	362304 (2)

See page 18 for Reference Drawing.

Liquiflo Chemical Processing Pumps™	H-Series Gear Pumps BOM: SEALED, LC Models H12R & H12F
--	---

Part Description	Drwg. Item #	316 Stainless Steel Construction			
		Code	Material	H12R	H12F
Position 9 – Bearing Flush Option (Front & Rear Housings)					
Front Housing, Std./EBF – SMS	8	0, 1 (Pos. 8 = U, S)	316 SS	990009	990009
Front Housing, Std./EBF – DMS	8	0, 1 (Pos. 8 = F, H)	316 SS	990090	990090
Front Housing, Std./EBF – Packing	8	0, 1 (Pos. 8 = L, R)	316 SS	990050	990050
Front Housing, IBF – SMS	8	2 (Pos. 8 = U, S)	316 SS	990011	990011
Front Housing, IBF – DMS	8	2 (Pos. 8 = F, H)	316 SS	990092	990092
Front Housing, IBF – Packing	8	2 (Pos. 8 = L, R)	316 SS	990070	990070
Rear Housing, Standard	2	0	316 SS	3120201	3120201
Rear Housing, EBF	2	1	316 SS	3120206	3120206
Rear Housing, IBF	2	2	316 SS	3120216	3120216
Plug, 1/8 NPT (Front Housing, Std./IBF)	9	0, 2	316 SS	362304 (1)	362304 (1)
Plug, 1/8 NPT (Front/Rear Housings/EBF)	9	1	316 SS	362304 (3)	362304 (3)
Position 10 – Shafts					
Drive Shaft, Uncoated	20	0	316 SS	990002	990002
Drive Shaft, CO-Coated	20	1	316 SS/CO	990002-CO	990002-CO
Drive Shaft, TC-Coated	20	2	316 SS/TC	990002-TC	990002-TC
Idler Shaft, Uncoated	1	0	316 SS	990000	990000
Idler Shaft, CO-Coated	1	1	316 SS/CO	990000-CO	990000-CO
Idler Shaft, TC-Coated	1	2	316 SS/TC	990000-TC	990000-TC
Position 11 – O-Rings					
O-ring, Housing (2-047)	5	0	Teflon	3121101 (2)	3121101 (2)
O-ring, Gland Plate (2-032; MS only)	10	0	Teflon	990035	990035
O-ring, Seal Seat, Outer (2-222; MS only)	18	0	Viton	990030	990030
O-ring, Seal Seat, Inner (2-030; DMS only)	27	0	Viton	3121561	3121561
O-ring, Housing (2-047)	5	6	Silicone/FEP	3121123 (2)	3121123 (2)
O-ring, Gland Plate (2-032; MS only)	10	6	Teflon	990035	990035
O-ring, Seal Seat, Outer (2-222; MS only)	18	6	Kalrez	990047	990047
O-ring, Seal Seat, Inner (2-030; DMS only)	27	6	Kalrez	3121564	3121564
O-ring, Housing (2-047)	5	B	Buna-N	3121105 (2)	3121105 (2)
O-ring, Gland Plate (2-032; MS only)	10	B	Buna-N	990046	990046
O-ring, Seal Seat, Outer (2-222; MS only)	18	B	Buna-N	990049	990049
O-ring, Seal Seat, Inner (2-030; DMS only)	27	B	Buna-N	3121563	3121563
O-ring, Housing (2-047)	5	E	EPDM	3121110 (2)	3121110 (2)
O-ring, Gland Plate (2-032; MS only)	10	E	EPDM	990034	990034
O-ring, Seal Seat, Outer (2-222; MS only)	18	E	EPDM	990031	990031
O-ring, Seal Seat, Inner (2-030; DMS only)	27	E	EPDM	3121562	3121562
O-ring, Housing (2-047)	5	V	Viton	3121112 (2)	3121112 (2)
O-ring, Gland Plate (2-032; MS only)	10	V	Viton	990033	990033
O-ring, Seal Seat, Outer (2-222; MS only)	18	V	Viton	990030	990030
O-ring, Seal Seat, Inner (2-030; DMS only)	27	V	Viton	3121561	3121561
O-ring, Housing (2-047)	5	K	Kalrez	3121116 (2)	3121116 (2)
O-ring, Gland Plate (2-032; MS only)	10	K	Kalrez	990048	990048
O-ring, Seal Seat, Outer (2-222; MS only)	18	K	Kalrez	990047	990047
O-ring, Seal Seat, Inner (2-030; DMS only)	27	K	Kalrez	3121564	3121564
Position 12 – Retaining Rings					
Retaining Ring, Gear	14	0	316 SS	990024 (4)	990024 (4)
Position 13 – Bearing Pins					
Pin, Bearing Lock	13	6	316 SS	3120801 (4)	3120801 (4)
Position 14 – Coupling Method					
Long-Coupled	-	1	-	X	X
Suffix – Trim Options					
Temperature Trim (Gears & Bearings)	-	-8(T) ¹	-	Consult Factory	
Viscosity Trim (Gears)	-	-9D, -9T	-		

1 - T = Application Temperature in °F (e.g., -8(300) = Temperature Trim at 300°F).

Liquiflo Chemical Processing Pumps™	H-Series Gear Pumps BOM: SEALED, LC Models H12R & H12F
---	---

Part Description	Drwg. Item #	Alloy-C Construction			
		Code	Material	H12R	H12F
Position 3 – Basic Material & Port Type (Center Housing, Alignment Pins, Coupling Key & Hardware)					
Center Housing, NPT	21	H	Alloy-C	3120005	3120005
Center Housing, Flanged (ANSI 150# RF)	21	C	Alloy-C	3120007	3120007
Center Housing, BSPT	21	Y	Alloy-C	3120009	3120009
Pin, Housing Alignment	12	H, C, Y	Alloy-C	3120803 (4)	3120803 (4)
Key, Mechanical Coupling (Pump Shaft)	28	H, C, Y	CS	3121900	3121900
Bolt, Housing (5/16-18 x 1 HHCS)	4	H, C, Y	18-8 SS	3122004 (12)	3122004 (12)
Lockwasher, Housing (5/16)	15	H, C, Y	18-8 SS	3126341 (12)	3126341 (12)
Position 4 – Drive Gear					
Gear	22	1	Alloy-C	990021	990017
Gear	22	3	Teflon	990058	990061
Gear	22	6	316 SS	X	X
Gear	22	K	Kynar	990085	990666
Gear	22	P	PEEK	990023	990019
Key, Gear	23	1, 3, K, P	Alloy-C	990027	990027
Position 5 – Idler Gear					
Gear	6	1	Alloy-C	990021	990017
Gear	6	3	Teflon	990058	990061
Gear	6	6	316 SS	X	X
Gear	6	8	Ryton	990022	990018
Gear	6	K	Kynar	990085	990666
Gear	6	P	PEEK	990023	990019
Key, Gear	24	1, 3, 8, K, P	Alloy-C	990027	990027
Position 6 – Wear Plates					
Wear Plate, Relieved	7	3	Teflon	3120522 (4)	3120505 (4)
Wear Plate, Relieved	7	4	SiC	3120513 (4)	3120507 (4)
Wear Plate, Relieved	7	E	Carbon 60	3120524 (4)	3120504 (4)
Wear Plate, Relieved	7	P	PEEK	3120502 (8)	3120502 (4)
Position 7 – Bearings					
Bearing	3	3	Teflon	990065 (4)	990065 (4)
Bearing	3	B	SiC	990006 (4)	990006 (4)
Bearing	3	E	Carbon 60	990008 (4)	990008 (4)
Bearing	3	P	PEEK	990007 (4)	990007 (4)
Position 8 – Seal Type					
Mechanical Seal, Single Internal	11	U	Alloy-C/Carbon	990029	990029
Mechanical Seal, Single Internal	11	S	Alloy-C/Teflon	990042	990042
Mechanical Seal, Double	11	F	316 SS/Carbon	990067	990067
Mechanical Seal, Double	11	H	316 SS/Teflon	990068	990068
Seal Seat, Outer	25	U, S, F, H	SiC	990062	990062
Seal Seat, Inner	26	F, H	SiC	990063	990063
Gland Plate, SMS	17	U, S	Alloy-C	990014	990014
Gland Plate, DMS	17	F, H	316 SS	990013	990013
Bolt, Gland (5/16-18 x 1 HHCS)	16	U, S, F, H	18-8 SS	3122004 (2)	3122004 (2)
Lockwasher, Gland (5/16)	19	U, S, F, H	18-8 SS	3126341 (2)	3126341 (2)
Plug, 1/8 NPT	9	U, S	Alloy-C	362301 (3)	362301 (3)
Plug, 1/8 NPT	9	F, H	Alloy-C	362301 (1)	362301 (1)
Packing Ring	18	L	Teflon	990055 (5)	990055 (5)
Packing Ring	18	R	Graphoil	990056 (5)	990056 (5)
Lantern Ring	11	L, R	Alloy-C	990054	990054
Gland Plate, PS	17	L, R	Alloy-C	990060	990060
Bolt, Gland (5/16-18 x 1 HHCS)	16	L, R	18-8 SS	3122004 (2)	3122004 (2)
Grease Fitting, 1/8 NPT	25	L, R	303 SS	867201	867201
Plug, 1/8 NPT	9	L, R	Alloy-C	362301 (2)	362301 (2)

See page 18 for Reference Drawing.

Liquiflo Chemical Processing Pumps™	H-Series Gear Pumps BOM: SEALED, LC Models H12R & H12F
--	---

Part Description	Drwg. Item #	Alloy-C Construction			
		Code	Material	H12R	H12F
Position 9 – Bearing Flush Option (Front & Rear Housings)					
Front Housing, Std./EBF – SMS	8	0, 1 (Pos. 8 = U, S)	Alloy-C	990010	990010
Front Housing, Std./EBF – DMS	8	0, 1 (Pos. 8 = F, H)	Alloy-C	990091	990091
Front Housing, Std./EBF – Packing	8	0, 1 (Pos. 8 = L, R)	Alloy-C	990051	990051
Front Housing, IBF – SMS	8	2 (Pos. 8 = U, S)	Alloy-C	990012	990012
Front Housing, IBF – DMS	8	2 (Pos. 8 = F, H)	Alloy-C	990093	990093
Front Housing, IBF – Packing	8	2 (Pos. 8 = L, R)	Alloy-C	990071	990071
Rear Housing, Standard	2	0	Alloy-C	3120205	3120205
Rear Housing, EBF	2	1	Alloy-C	3120207	3120207
Rear Housing, IBF	2	2	Alloy-C	3120217	3120217
Plug, 1/8 NPT (Front Housing, Std./IBF)	9	0, 2	Alloy-C	362301 (1)	362301 (1)
Plug, 1/8 NPT (Front/Rear Housings/EBF)	9	1	Alloy-C	362301 (3)	362301 (3)
Position 10 – Shafts					
Drive Shaft, Uncoated	20	0	Alloy-C	990003	990003
Drive Shaft, CO-Coated	20	1	Alloy-C/CO	990003-CO	990003-CO
Drive Shaft, TC-Coated	20	2	Alloy-C/TC	990003-TC	990003-TC
Idler Shaft, Uncoated	1	0	Alloy-C	990001	990001
Idler Shaft, CO-Coated	1	1	Alloy-C/CO	990001-CO	990001-CO
Idler Shaft, TC-Coated	1	2	Alloy-C/TC	990001-TC	990001-TC
Position 11 – O-Rings					
O-ring, Housing (2-047)	5	0	Teflon	3121101 (2)	3121101 (2)
O-ring, Gland Plate (2-032; MS only)	10	0	Teflon	990035	990035
O-ring, Seal Seat, Outer (2-222; MS only)	18	0	Viton	990030	990030
O-ring, Seal Seat, Inner (2-030; DMS only)	27	0	Viton	3121561	3121561
O-ring, Housing (2-047)	5	6	Silicone/FEP	3121123 (2)	3121123 (2)
O-ring, Gland Plate (2-032; MS only)	10	6	Teflon	990035	990035
O-ring, Seal Seat, Outer (2-222; MS only)	18	6	Kalrez	990047	990047
O-ring, Seal Seat, Inner (2-030; DMS only)	27	6	Kalrez	3121564	3121564
O-ring, Housing (2-047)	5	B	Buna-N	3121105 (2)	3121105 (2)
O-ring, Gland Plate (2-032; MS only)	10	B	Buna-N	990046	990046
O-ring, Seal Seat, Outer (2-222; MS only)	18	B	Buna-N	990049	990049
O-ring, Seal Seat, Inner (2-030; DMS only)	27	B	Buna-N	3121563	3121563
O-ring, Housing (2-047)	5	E	EPDM	3121110 (2)	3121110 (2)
O-ring, Gland Plate (2-032; MS only)	10	E	EPDM	990034	990034
O-ring, Seal Seat, Outer (2-222; MS only)	18	E	EPDM	990031	990031
O-ring, Seal Seat, Inner (2-030; DMS only)	27	E	EPDM	3121562	3121562
O-ring, Housing (2-047)	5	V	Viton	3121112 (2)	3121112 (2)
O-ring, Gland Plate (2-032; MS only)	10	V	Viton	990033	990033
O-ring, Seal Seat, Outer (2-222; MS only)	18	V	Viton	990030	990030
O-ring, Seal Seat, Inner (2-030; DMS only)	27	V	Viton	3121561	3121561
O-ring, Housing (2-047)	5	K	Kalrez	3121116 (2)	3121116 (2)
O-ring, Gland Plate (2-032; MS only)	10	K	Kalrez	990048	990048
O-ring, Seal Seat, Outer (2-222; MS only)	18	K	Kalrez	990047	990047
O-ring, Seal Seat, Inner (2-030; DMS only)	27	K	Kalrez	3121564	3121564
Position 12 – Retaining Rings					
Retaining Ring, Gear	14	0	Alloy-C	990025 (4)	990025 (4)
Position 13 – Bearing Pins					
Pin, Bearing Lock	13	1	Alloy-C	3120803 (4)	3120803 (4)
Position 14 – Coupling Method					
Long-Coupled	-	1	-	X	X
Suffix – Trim Options					
Temperature Trim (Gears & Bearings)	-	-8(T) ¹	-	Consult Factory	
Viscosity Trim (Gears)	-	-9D, -9T	-		

1 - T = Application Temperature in °F (e.g., -8(300) = Temperature Trim at 300°F).

Liquiflo Chemical Processing Pumps™	H-Series Gear Pumps BOM: MAG-DRIVE, LC Models H12R & H12F
---	--

Part Description	Drwg. Item #	316 Stainless Steel Construction			
		Code	Material	H12R	H12F
Position 3 – Basic Material & Port Type (Center Housing, Alignment Pins, Coupling Key & Hardware)					
Center Housing, NPT	21	S	316 SS	3120004	3120004
Center Housing, Flanged (ANSI 150# RF)	21	L	316 SS	3120003	3120003
Center Housing, BSPT	21	X	316 SS	3120008	3120008
Pin, Housing Alignment	34	S, L, X	316 SS	3120801 (4)	3120801 (4)
Key, Mechanical Coupling (Pump Shaft)	32	S, L, X	CS	S3140078	S3140078
Bolt, Housing (5/16-18 x 1 HHCS)	4	S, L, X	18-8 SS	3122004 (12)	3122004 (12)
Lockwasher, Housing (5/16)	31	S, L, X	18-8 SS	3126341 (12)	3126341 (12)
Screw, C. Can (5/16-24 x 5/8 FH-SHCS)	18	S, L, X	18-8 SS	S641109 (8)	S641109 (8)
Position 4 – Drive Gear					
Gear	22	1	Alloy-C	990021	990017
Gear	22	3	Teflon	990058	990061
Gear	22	6	316 SS	990020	990016
Gear	22	K	Kynar	990085	990666
Gear	22	P	PEEK	990023	990019
Key, Gear	23	1, 3, 6, K, P	316 SS	990026	990026
Position 5 – Idler Gear					
Gear	6	1	Alloy-C	990021	990017
Gear	6	3	Teflon	990058	990061
Gear	6	6	316 SS	990020	990016
Gear	6	8	Ryton	990022	990018
Gear	6	K	Kynar	990085	990666
Gear	6	P	PEEK	990023	990019
Key, Gear	24	1, 3, 6, 8, K, P	316 SS	990026	990026
Position 6 – Wear Plates					
Wear Plate, Relieved	7	3	Teflon	3120522 (4)	3120505 (4)
Wear Plate, Relieved	7	4	SiC	3120513 (4)	3120507 (4)
Wear Plate, Relieved	7	E	Carbon 60	3120524 (4)	3120504 (4)
Wear Plate, Relieved	7	P	PEEK	3120502 (8)	3120502 (4)
Position 7 – Bearings					
Bearing	3	3	Teflon	990065 (4)	990065 (4)
Bearing	3	B	SiC	990006 (4)	990006 (4)
Bearing	3	E	Carbon 60	990008 (4)	990008 (4)
Bearing	3	P	PEEK	990007 (4)	990007 (4)
Position 8 – Outer Magnet Shaft					
7/8" Diameter Stub Shaft	16	1	See Outer Magnet, Position 14		
Position 9 – Bearing Flush Option (Front & Rear Housings)					
Front Housing, MC, Std./EBF	8	0, 1	316 SS	S3120130	S3120130
Front Housing, MC, IBF	8	2	316 SS	S3120132	S3120132
Rear Housing, Standard	2	0	316 SS	3120201	3120201
Rear Housing, EBF	2	1	316 SS	3120206	3120206
Rear Housing, IBF	2	2	316 SS	3120216	3120216
Plug, 1/8 NPT (Front Housing, Std./IBF)	9	0, 2	316 SS	362304 (1)	362304 (1)
Plug, 1/8 NPT (Front/Rear Housings/EBF)	9	1	316 SS	362304 (3)	362304 (3)
Position 10 – Shafts					
Drive Shaft, MC, Uncoated	20	0	316 SS	990004	990004
Drive Shaft, MC, CO-Coated	20	1	316 SS/CO	990004-CO	990004-CO
Drive Shaft, MC, TC-Coated	20	2	316 SS/TC	990004-TC	990004-TC
Idler Shaft, Uncoated	1	0	316 SS	990000	990000
Idler Shaft, CO-Coated	1	1	316 SS/CO	990000-CO	990000-CO
Idler Shaft, TC-Coated	1	2	316 SS/TC	990000-TC	990000-TC

See page 19 for Reference Drawing.

Liquiflo Chemical Processing Pumps™	H-Series Gear Pumps BOM: MAG-DRIVE, LC Models H12R & H12F
---	--

Part Description	Drwg. Item #	316 Stainless Steel Construction			
		Code	Material	H12R	H12F
Position 11 – O-Rings					
O-ring, Housing (2-047)	5	0	Teflon	3121101 (2)	3121101 (2)
O-ring, Containment Can (2-049)	19	0	Teflon	3121103	3121103
O-ring, Housing (2-047)	5	6	Silicone/FEP	3121123 (2)	3121123 (2)
O-ring, Containment Can (2-049)	19	6	Silicone/FEP	3121124	3121124
O-ring, Housing (2-047)	5	B	Buna-N	3121105 (2)	3121105 (2)
O-ring, Containment Can (2-049)	19	B	Buna-N	3121115	3121115
O-ring, Housing (2-047)	5	E	EPDM	3121110 (2)	3121110 (2)
O-ring, Containment Can (2-049)	19	E	EPDM	3121111	3121111
O-ring, Housing (2-047)	5	V	Viton	3121112 (2)	3121112 (2)
O-ring, Containment Can (2-049)	19	V	Viton	3121119	3121119
O-ring, Housing (2-047)	5	K	Kalrez	3121116 (2)	3121116 (2)
O-ring, Containment Can (2-049)	19	K	Kalrez	3121117	3121117
Position 12 – Retaining Rings					
Retaining Ring, Gear	29	0	316 SS	990024 (4)	990024 (4)
Retaining Ring, Inner Magnet	25	0	316 SS	S3146702	S3146702
Position 13 – Bearing Pins					
Pin, Bearing Lock	26	6	316 SS	3120801 (4)	3120801 (4)
Position 14 – Magnetic Coupling					
Inner Magnet, MCK – 7/8" Bore	11	K	316 SS/SmCo	SIMCK-07	SIMCK-07
Outer Magnet, MCK – 7/8" Stub Shaft	10	K	CS/SmCo	SOMCK-7B	SOMCK-7B
Inner Magnet, MCJ – 7/8" Bore	11	J	316 SS/SmCo	SIMCJ-07	SIMCJ-07
Outer Magnet, MCJ – 7/8" Stub Shaft	10	J	CS/SmCo	SOMCJ-7B	SOMCJ-7B
Key, Inner Magnet	13	K, J	316 SS	S3140079	S3140079
Position 15 – Containment Can					
Containment Can, Single Wall	12	S	316 SS	S3142004	S3142004
Dual Kan Option (Modified Parts)	12	D	316 SS	Consult Factory	
Suffix – Trim Options					
Temperature Trim (Gears & Bearings)	–	–8(T) ¹	–	Consult Factory	
Viscosity Trim (Gears)	–	–9D, –9T	–		

1 - T = Application Temperature in °F (e.g., -8(300) = Temperature Trim at 300°F).

Liquiflo Chemical Processing Pumps™	H-Series Gear Pumps BOM: MAG-DRIVE, LC Models H12R & H12F
---	--

Part Description	Drwg. Item #	Alloy-C Construction			
		Code	Material	H12R	H12F
Position 3 – Basic Material & Port Type (Center Housing, Alignment Pins, Coupling Key & Hardware)					
Center Housing, NPT	21	H	Alloy-C	3120005	3120005
Center Housing, Flanged (ANSI 150# RF)	21	C	Alloy-C	3120007	3120007
Center Housing, BSPT	21	Y	Alloy-C	3120009	3120009
Pin, Housing Alignment	34	H, C, Y	Alloy-C	3120803 (4)	3120803 (4)
Key, Mechanical Coupling (Pump Shaft)	32	H, C, Y	CS	S3140078	S3140078
Bolt, Housing (5/16-18 x 1 HHCS)	4	H, C, Y	18-8 SS	3122004 (12)	3122004 (12)
Lockwasher, Housing (5/16)	31	H, C, Y	18-8 SS	3126341 (12)	3126341 (12)
Screw, C. Can (5/16-24 x 5/8 FH-SHCS)	18	H, C, Y	18-8 SS	S641109 (8)	S641109 (8)
Position 4 – Drive Gear					
Gear	22	1	Alloy-C	990021	990017
Gear	22	3	Teflon	990058	990061
Gear	22	6	316 SS	X	X
Gear	22	K	Kynar	990085	990666
Gear	22	P	PEEK	990023	990019
Key, Gear	23	1, 3, K, P	Alloy-C	990027	990027
Position 5 – Idler Gear					
Gear	6	1	Alloy-C	990021	990017
Gear	6	3	Teflon	990058	990061
Gear	6	6	316 SS	X	X
Gear	6	8	Ryton	990022	990018
Gear	6	K	Kynar	990085	990666
Gear	6	P	PEEK	990023	990019
Key, Gear	24	1, 3, 8, K, P	Alloy-C	990027	990027
Position 6 – Wear Plates					
Wear Plate, Relieved	7	3	Teflon	3120522 (4)	3120505 (4)
Wear Plate, Relieved	7	4	SiC	3120513 (4)	3120507 (4)
Wear Plate, Relieved	7	E	Carbon 60	3120524 (4)	3120504 (4)
Wear Plate, Relieved	7	P	PEEK	3120502 (8)	3120502 (4)
Position 7 – Bearings					
Bearing	3	3	Teflon	990065 (4)	990065 (4)
Bearing	3	B	SiC	990006 (4)	990006 (4)
Bearing	3	E	Carbon 60	990008 (4)	990008 (4)
Bearing	3	P	PEEK	990007 (4)	990007 (4)
Position 8 – Outer Magnet Shaft					
7/8" Diameter Stub Shaft	16	1	See Outer Magnet, Position 14		
Position 9 – Bearing Flush Option (Front & Rear Housings)					
Front Housing, MC, Std./EBF	8	0, 1	Alloy-C	S3120131	S3120131
Front Housing, MC, IBF	8	2	Alloy-C	S3120133	S3120133
Rear Housing, Standard	2	0	Alloy-C	3120205	3120205
Rear Housing, EBF	2	1	Alloy-C	3120207	3120207
Rear Housing, IBF	2	2	Alloy-C	3120217	3120217
Plug, 1/8 NPT (Front Housing, Std./IBF)	9	0, 2	Alloy-C	362301 (1)	362301 (1)
Plug, 1/8 NPT (Front/Rear Housings/EBF)	9	1	Alloy-C	362301 (3)	362301 (3)
Position 10 – Shafts					
Drive Shaft, MC, Uncoated	20	0	Alloy-C	990005	990005
Drive Shaft, MC, CO-Coated	20	1	Alloy-C/CO	990005-CO	990005-CO
Drive Shaft, MC, TC-Coated	20	2	Alloy-C/TC	990005-TC	990005-TC
Idler Shaft, Uncoated	1	0	Alloy-C	990001	990001
Idler Shaft, CO-Coated	1	1	Alloy-C/CO	990001-CO	990001-CO
Idler Shaft, TC-Coated	1	2	Alloy-C/TC	990001-TC	990001-TC

See page 19 for Reference Drawing.

Liquiflo Chemical Processing Pumps™	H-Series Gear Pumps BOM: MAG-DRIVE, LC Models H12R & H12F
---	--

Part Description	Drwg. Item #	Alloy-C Construction			
		Code	Material	H12R	H12F
Position 11 – O-Rings					
O-ring, Housing (2-047)	5	0	Teflon	3121101 (2)	3121101 (2)
O-ring, Containment Can (2-049)	19	0	Teflon	3121103	3121103
O-ring, Housing (2-047)	5	6	Silicone/FEP	3121123 (2)	3121123 (2)
O-ring, Containment Can (2-049)	19	6	Silicone/FEP	3121124	3121124
O-ring, Housing (2-047)	5	B	Buna-N	3121105 (2)	3121105 (2)
O-ring, Containment Can (2-049)	19	B	Buna-N	3121115	3121115
O-ring, Housing (2-047)	5	E	EPDM	3121110 (2)	3121110 (2)
O-ring, Containment Can (2-049)	19	E	EPDM	3121111	3121111
O-ring, Housing (2-047)	5	V	Viton	3121112 (2)	3121112 (2)
O-ring, Containment Can (2-049)	19	V	Viton	3121119	3121119
O-ring, Housing (2-047)	5	K	Kalrez	3121116 (2)	3121116 (2)
O-ring, Containment Can (2-049)	19	K	Kalrez	3121117	3121117
Position 12 – Retaining Rings					
Retaining Ring, Gear	29	0	Alloy-C	990025 (4)	990025 (4)
Retaining Ring, Inner Magnet	25	0	Alloy-C	S3146709	S3146709
Position 13 – Bearing Pins					
Pin, Bearing Lock	26	1	Alloy-C	3120803 (4)	3120803 (4)
Position 14 – Magnetic Coupling					
Inner Magnet, MCK – 7/8" Bore	11	K	Alloy-C/SmCo	SIMCK-17	SIMCK-17
Outer Magnet, MCK – 7/8" Stub Shaft	10	K	CS/SmCo	SOMCK-7B	SOMCK-7B
Inner Magnet, MCJ – 7/8" Bore	11	J	Alloy-C/SmCo	SIMCJ-17	SIMCJ-17
Outer Magnet, MCJ – 7/8" Stub Shaft	10	J	CS/SmCo	SOMCJ-7B	SOMCJ-7B
Key, Inner Magnet	13	K, J	Alloy-C	S3140080	S3140080
Position 15 – Containment Can					
Containment Can, Single Wall	12	S	Alloy-C	S3142003	S3142003
Dual Kan Option (Modified Parts)	12	D	Alloy-C	Consult Factory	
Suffix – Trim Options					
Temperature Trim (Gears & Bearings)	-	-8(T) ¹	-	Consult Factory	
Viscosity Trim (Gears)	-	-9D, -9T	-		

1 - T = Application Temperature in °F (e.g., -8(300) = Temperature Trim at 300°F).

Liquiflo Chemical Processing Pumps™	H-Series Gear Pumps BOM: SEALED, CC Models H12R & H12F
--	---

Part Description	Drwg. Item #	316 Stainless Steel Construction			
		Code	Material	H12R	H12F
Position 3 – Basic Material & Port Type (Center Housing, Alignment Pins, Coupling Key & Hardware)					
Center Housing, NPT	21	S	316 SS	3120004	3120004
Center Housing, Flanged (ANSI 150# RF)	21	L	316 SS	3120003	3120003
Center Housing, BSPT	21	X	316 SS	3120008	3120008
Pin, Housing Alignment	12	S, L, X	316 SS	3120801 (4)	3120801 (4)
Key, Mechanical Coupling (Pump Shaft)	28	S, L, X	CS	3121900	3121900
Bolt, Housing (5/16-18 x 1 HHCS)	14	S, L, X	18-8 SS	3122004 (12)	3122004 (12)
Lockwasher, Housing (5/16)	15	S, L, X	18-8 SS	3126341 (12)	3126341 (12)
Position 4 – Drive Gear					
Gear	22	1	Alloy-C	990021	990017
Gear	22	3	Teflon	990058	990061
Gear	22	6	316 SS	990020	990016
Gear	22	K	Kynar	990085	990666
Gear	22	P	PEEK	990023	990019
Key, Gear	23	1, 3, 6, K, P	316 SS	990026	990026
Position 5 – Idler Gear					
Gear	6	1	Alloy-C	990021	990017
Gear	6	3	Teflon	990058	990061
Gear	6	6	316 SS	990020	990016
Gear	6	8	Ryton	990022	990018
Gear	6	K	Kynar	990085	990666
Gear	6	P	PEEK	990023	990019
Key, Gear	24	1, 3, 6, 8, K, P	316 SS	990026	990026
Position 6 – Wear Plates					
Wear Plate, Relieved	7	3	Teflon	3120522 (4)	3120505 (4)
Wear Plate, Relieved	7	4	SiC	3120513 (4)	3120507 (4)
Wear Plate, Relieved	7	E	Carbon 60	3120524 (4)	3120504 (4)
Wear Plate, Relieved	7	P	PEEK	3120502 (8)	3120502 (4)
Position 7 – Bearings					
Bearing	3	3	Teflon	990065 (4)	990065 (4)
Bearing	3	B	SiC	990006 (4)	990006 (4)
Bearing	3	E	Carbon 60	990008 (4)	990008 (4)
Bearing	3	P	PEEK	990007 (4)	990007 (4)
Position 8 – Seal Type					
Mechanical Seal, Single Internal	11	U	316 SS/Carbon	990028	990028
Mechanical Seal, Single Internal	11	S	316 SS/Teflon	990041	990041
Mechanical Seal, Double	11	F	316 SS/Carbon	990067	990067
Mechanical Seal, Double	11	H	316 SS/Teflon	990068	990068
Seal Seat, Outer	25	U, S, F, H	SiC	990062	990062
Seal Seat, Inner	26	F, H	SiC	990063	990063
Gland Plate, SMS & DMS	17	U, S, F, H	316 SS	990013	990013
Bolt, Gland (5/16-18 x 1 HHCS)	16	U, S, F, H	18-8 SS	3122004 (2)	3122004 (2)
Lockwasher, Gland (5/16)	19	U, S, F, H	18-8 SS	3126341 (2)	3126341 (2)
Plug, 1/8 NPT (Front Housing)	9	U, S	316 SS	362304 (2)	362304 (2)
Packing Ring	18	L	Teflon	990055 (5)	990055 (5)
Packing Ring	18	R	Graphoil	990056 (5)	990056 (5)
Lantern Ring	11	L, R	316 SS	990053	990053
Gland Plate, PS	17	L, R	316 SS	990057	990057
Bolt, Gland (5/16-18 x 1 HHCS)	16	L, R	18-8 SS	3122004 (2)	3122004 (2)
Grease Fitting, 1/8 NPT (Front Housing)	25	L, R	303 SS	867201 (1)	867201 (1)
Plug, 1/8 NPT (Front Housing)	9	L, R	316 SS	362304 (2)	362304 (2)

See page 20 for Reference Drawing.

Liquiflo Chemical Processing Pumps™	H-Series Gear Pumps BOM: SEALED, CC Models H12R & H12F
--	---

Part Description	Drwg. Item #	316 Stainless Steel Construction			
		Code	Material	H12R	H12F
Position 9 – Bearing Flush Option (Front & Rear Housings)					
Front Housing, CC, Std./EBF – SMS/DMS	8	0, 1 (Pos. 8 = U,S,F,H)	316 SS	3120122	3120122
Front Housing, CC, Std./EBF – Packing	8	0, 1 (Pos. 8 = L, R)	316 SS	3120110	3120110
Front Housing, CC, IBF – SMS/DMS	8	2 (Pos. 8 = U,S,F,H)	316 SS	3120128	3120128
Front Housing, CC, IBF – Packing	8	2 (Pos. 8 = L, R)	316 SS	3120140	3120140
Rear Housing, Standard	2	0	316 SS	3120201	3120201
Rear Housing, EBF	2	1	316 SS	3120206	3120206
Rear Housing, IBF	2	2	316 SS	3120216	3120216
Plug, 1/8 NPT (Rear Housing, EBF)	9	1	316 SS	362304 (2)	362304 (2)
Position 10 – Shafts					
Drive Shaft, Uncoated	20	0	316 SS	990080	990080
Drive Shaft, CO-Coated	20	1	316 SS/CO	990080-CO	990080-CO
Drive Shaft, TC-Coated	20	2	316 SS/TC	990080-TC	990080-TC
Idler Shaft, Uncoated	1	0	316 SS	990000	990000
Idler Shaft, CO-Coated	1	1	316 SS/CO	990000-CO	990000-CO
Idler Shaft, TC-Coated	1	2	316 SS/TC	990000-TC	990000-TC
Position 11 – O-Rings					
O-ring, Housing (2-047)	5	0	Teflon	3121101 (2)	3121101 (2)
O-ring, Gland Plate (2-032; MS only)	10	0	Teflon	990035	990035
O-ring, Seal Seat, Outer (2-222; MS only)	18	0	Viton	990030	990030
O-ring, Seal Seat, Inner (2-030; DMS only)	27	0	Viton	3121561	3121561
O-ring, Housing (2-047)	5	6	Silicone/FEP	3121123 (2)	3121123 (2)
O-ring, Gland Plate (2-032; MS only)	10	6	Teflon	990035	990035
O-ring, Seal Seat, Outer (2-222; MS only)	18	6	Kalrez	990047	990047
O-ring, Seal Seat, Inner (2-030; DMS only)	27	6	Kalrez	3121564	3121564
O-ring, Housing (2-047)	5	B	Buna-N	3121105 (2)	3121105 (2)
O-ring, Gland Plate (2-032; MS only)	10	B	Buna-N	990046	990046
O-ring, Seal Seat, Outer (2-222; MS only)	18	B	Buna-N	990049	990049
O-ring, Seal Seat, Inner (2-030; DMS only)	27	B	Buna-N	3121563	3121563
O-ring, Housing (2-047)	5	E	EPDM	3121110 (2)	3121110 (2)
O-ring, Gland Plate (2-032; MS only)	10	E	EPDM	990034	990034
O-ring, Seal Seat, Outer (2-222; MS only)	18	E	EPDM	990031	990031
O-ring, Seal Seat, Inner (2-030; DMS only)	27	E	EPDM	3121562	3121562
O-ring, Housing (2-047)	5	V	Viton	3121112 (2)	3121112 (2)
O-ring, Gland Plate (2-032; MS only)	10	V	Viton	990033	990033
O-ring, Seal Seat, Outer (2-222; MS only)	18	V	Viton	990030	990030
O-ring, Seal Seat, Inner (2-030; DMS only)	27	V	Viton	3121561	3121561
O-ring, Housing (2-047)	5	K	Kalrez	3121116 (2)	3121116 (2)
O-ring, Gland Plate (2-032; MS only)	10	K	Kalrez	990048	990048
O-ring, Seal Seat, Outer (2-222; MS only)	18	K	Kalrez	990047	990047
O-ring, Seal Seat, Inner (2-030; DMS only)	27	K	Kalrez	3121564	3121564
Position 12 – Retaining Rings					
Retaining Ring, Gear	4	0	316 SS	990024 (4)	990024 (4)
Position 13 – Bearing Pins					
Pin, Bearing Lock	13	6	316 SS	3120801 (4)	3120801 (4)
Position 14 – Coupling Method (Mechanical Coupling, Bracket, Hardware & Adapter)					
Close-Coupled (Additional Parts)	-	5 thru 9	-	See Appendix 3	
Suffix – Trim Options					
Temperature Trim (Gears & Bearings)	-	-8(T) ¹	-	Consult Factory	
Viscosity Trim (Gears)	-	-9D, -9T	-		

1 - T = Application Temperature in °F (e.g., -8(300) = Temperature Trim at 300°F).

Liquiflo Chemical Processing Pumps™	H-Series Gear Pumps BOM: SEALED, CC Models H12R & H12F
--	---

Part Description	Drwg. Item #	Alloy-C Construction			
		Code	Material	H12R	H12F
Position 3 – Basic Material & Port Type (Center Housing, Alignment Pins, Coupling Key & Hardware)					
Center Housing, NPT	21	H	Alloy-C	3120005	3120005
Center Housing, Flanged (ANSI 150# RF)	21	C	Alloy-C	3120007	3120007
Center Housing, BSPT	21	Y	Alloy-C	3120009	3120009
Pin, Housing Alignment	12	H, C, Y	Alloy-C	3120803 (4)	3120803 (4)
Key, Mechanical Coupling (Pump Shaft)	28	H, C, Y	CS	3121900	3121900
Bolt, Housing (5/16-18 x 1 HHCS)	14	H, C, Y	18-8 SS	3122004 (12)	3122004 (12)
Lockwasher, Housing (5/16)	15	H, C, Y	18-8 SS	3126341 (12)	3126341 (12)
Position 4 – Drive Gear					
Gear	22	1	Alloy-C	990021	990017
Gear	22	3	Teflon	990058	990061
Gear	22	6	316 SS	X	X
Gear	22	K	Kynar	990085	990666
Gear	22	P	PEEK	990023	990019
Key, Gear	23	1, 3, K, P	Alloy-C	990027	990027
Position 5 – Idler Gear					
Gear	6	1	Alloy-C	990021	990017
Gear	6	3	Teflon	990058	990061
Gear	6	6	316 SS	X	X
Gear	6	8	Ryton	990022	990018
Gear	6	K	Kynar	990085	990666
Gear	6	P	PEEK	990023	990019
Key, Gear	24	1, 3, 8, K, P	Alloy-C	990027	990027
Position 6 – Wear Plates					
Wear Plate, Relieved	7	3	Teflon	3120522 (4)	3120505 (4)
Wear Plate, Relieved	7	4	SiC	3120513 (4)	3120507 (4)
Wear Plate, Relieved	7	E	Carbon 60	3120524 (4)	3120504 (4)
Wear Plate, Relieved	7	P	PEEK	3120502 (8)	3120502 (4)
Position 7 – Bearings					
Bearing	3	3	Teflon	990065 (4)	990065 (4)
Bearing	3	B	SiC	990006 (4)	990006 (4)
Bearing	3	E	Carbon 60	990008 (4)	990008 (4)
Bearing	3	P	PEEK	990007 (4)	990007 (4)
Position 8 – Seal Type					
Mechanical Seal, Single Internal	11	U	Alloy-C/Carbon	990029	990029
Mechanical Seal, Single Internal	11	S	Alloy-C/Teflon	990042	990042
Mechanical Seal, Double	11	F	316 SS/Carbon	990067	990067
Mechanical Seal, Double	11	H	316 SS/Teflon	990068	990068
Seal Seat, Outer	25	U, S, F, H	SiC	990062	990062
Seal Seat, Inner	26	F, H	SiC	990063	990063
Gland Plate, SMS	17	U, S	Alloy-C	990014	990014
Gland Plate, DMS	17	F, H	316 SS	990013	990013
Bolt, Gland (5/16-18 x 1 HHCS)	16	U, S, F, H	18-8 SS	3122004 (2)	3122004 (2)
Lockwasher, Gland (5/16)	19	U, S, F, H	18-8 SS	3126341 (2)	3126341 (2)
Plug, 1/8 NPT (Front Housing)	9	U, S	Alloy-C	362301 (2)	362301 (2)
Packing Ring	18	L	Teflon	990055 (5)	990055 (5)
Packing Ring	18	R	Graphoil	990056 (5)	990056 (5)
Lantern Ring	11	L, R	Alloy-C	990054	990054
Gland Plate, PS	17	L, R	Alloy-C	990060	990060
Bolt, Gland (5/16-18 x 1 HHCS)	16	L, R	18-8 SS	3122004 (2)	3122004 (2)
Grease Fitting, 1/8 NPT (Front Housing)	25	L, R	303 SS	867201 (1)	867201 (1)
Plug, 1/8 NPT (Front Housing)	9	L, R	Alloy-C	362301 (2)	362301 (2)

See page 20 for Reference Drawing.

Liquiflo Chemical Processing Pumps™	H-Series Gear Pumps BOM: SEALED, CC Models H12R & H12F
--	---

Part Description	Drwg. Item #	Alloy-C Construction			
		Code	Material	H12R	H12F
Position 9 – Bearing Flush Option (Front & Rear Housings)					
Front Housing, CC, Std./EBF – SMS/DMS	8	0, 1 (Pos. 8 = U,S,F,H)	Alloy-C	3120123	3120123
Front Housing, CC, Std./EBF – Packing	8	0, 1 (Pos. 8 = L, R)	Alloy-C	3120111	3120111
Front Housing, CC, IBF – SMS/DMS	8	2 (Pos. 8 = U,S,F,H)	Alloy-C	3120129	3120129
Front Housing, CC, IBF – Packing	8	2 (Pos. 8 = L, R)	Alloy-C	3120141	3120141
Rear Housing, Standard	2	0	Alloy-C	3120205	3120205
Rear Housing, EBF	2	1	Alloy-C	3120207	3120207
Rear Housing, IBF	2	2	Alloy-C	3120217	3120217
Plug, 1/8 NPT (Rear Housing, EBF)	9	1	Alloy-C	362301 (2)	362301 (2)
Position 10 – Shafts					
Drive Shaft, Uncoated	20	0	Alloy-C	990081	990081
Drive Shaft, CO-Coated	20	1	Alloy-C/CO	990081-CO	990081-CO
Drive Shaft, TC-Coated	20	2	Alloy-C/TC	990081-TC	990081-TC
Idler Shaft, Uncoated	1	0	Alloy-C	990001	990001
Idler Shaft, CO-Coated	1	1	Alloy-C/CO	990001-CO	990001-CO
Idler Shaft, TC-Coated	1	2	Alloy-C/TC	990001-TC	990001-TC
Position 11 – O-Rings					
O-ring, Housing (2-047)	5	0	Teflon	3121101 (2)	3121101 (2)
O-ring, Gland Plate (2-032; MS only)	10	0	Teflon	990035	990035
O-ring, Seal Seat, Outer (2-222; MS only)	18	0	Viton	990030	990030
O-ring, Seal Seat, Inner (2-030; DMS only)	27	0	Viton	3121561	3121561
O-ring, Housing (2-047)	5	6	Silicone/FEP	3121123 (2)	3121123 (2)
O-ring, Gland Plate (2-032; MS only)	10	6	Teflon	990035	990035
O-ring, Seal Seat, Outer (2-222; MS only)	18	6	Kalrez	990047	990047
O-ring, Seal Seat, Inner (2-030; DMS only)	27	6	Kalrez	3121564	3121564
O-ring, Housing (2-047)	5	B	Buna-N	3121105 (2)	3121105 (2)
O-ring, Gland Plate (2-032; MS only)	10	B	Buna-N	990046	990046
O-ring, Seal Seat, Outer (2-222; MS only)	18	B	Buna-N	990049	990049
O-ring, Seal Seat, Inner (2-030; DMS only)	27	B	Buna-N	3121563	3121563
O-ring, Housing (2-047)	5	E	EPDM	3121110 (2)	3121110 (2)
O-ring, Gland Plate (2-032; MS only)	10	E	EPDM	990034	990034
O-ring, Seal Seat, Outer (2-222; MS only)	18	E	EPDM	990031	990031
O-ring, Seal Seat, Inner (2-030; DMS only)	27	E	EPDM	3121562	3121562
O-ring, Housing (2-047)	5	V	Viton	3121112 (2)	3121112 (2)
O-ring, Gland Plate (2-032; MS only)	10	V	Viton	990033	990033
O-ring, Seal Seat, Outer (2-222; MS only)	18	V	Viton	990030	990030
O-ring, Seal Seat, Inner (2-030; DMS only)	27	V	Viton	3121561	3121561
O-ring, Housing (2-047)	5	K	Kalrez	3121116 (2)	3121116 (2)
O-ring, Gland Plate (2-032; MS only)	10	K	Kalrez	990048	990048
O-ring, Seal Seat, Outer (2-222; MS only)	18	K	Kalrez	990047	990047
O-ring, Seal Seat, Inner (2-030; DMS only)	27	K	Kalrez	3121564	3121564
Position 12 – Retaining Rings					
Retaining Ring, Gear	4	0	Alloy-C	990025 (4)	990025 (4)
Position 13 – Bearing Pins					
Pin, Bearing Lock	13	1	Alloy-C	3120803 (4)	3120803 (4)
Position 14 – Coupling Method (Mechanical Coupling, Bracket, Hardware & Adapter)					
Close-Coupled (Additional Parts)	–	5 thru 9	–	See Appendix 3	
Suffix – Trim Options					
Temperature Trim (Gears & Bearings)	–	-8(T) ¹	–	Consult Factory	
Viscosity Trim (Gears)	–	-9D, -9T	–		

1 - T = Application Temperature in °F (e.g., -8(300) = Temperature Trim at 300°F).

Liquiflo Chemical Processing Pumps™	H-Series Gear Pumps BOM: MAG-DRIVE, CC Models H12R & H12F
---	--

Part Description	Drwg. Item #	316 Stainless Steel Construction			
		Code	Material	H12R	H12F
Position 3 – Basic Material & Port Type (Center Housing, Alignment Pins & Hardware)					
Center Housing, NPT	21	S	316 SS	3120004	3120004
Center Housing, Flanged (ANSI 150# RF)	21	L	316 SS	3120003	3120003
Center Housing, BSPT	21	X	316 SS	3120008	3120008
Pin, Housing Alignment	27	S, L, X	316 SS	3120801 (4)	3120801 (4)
Bolt, Housing (5/16-18 x 1 HHCS)	14	S, L, X	18-8 SS	3122004 (12)	3122004 (12)
Lockwasher, Housing (5/16)	15	S, L, X	18-8 SS	3126341 (12)	3126341 (12)
Screw, C. Can (5/16-24 x 5/8 FH-SHCS)	18	S, L, X	18-8 SS	S641109 (8)	S641109 (8)
Position 4 – Drive Gear					
Gear	22	1	Alloy-C	990021	990017
Gear	22	3	Teflon	990058	990061
Gear	22	6	316 SS	990020	990016
Gear	22	K	Kynar	990085	990666
Gear	22	P	PEEK	990023	990019
Key, Gear	23	1, 3, 6, K, P	316 SS	990026	990026
Position 5 – Idler Gear					
Gear	6	1	Alloy-C	990021	990017
Gear	6	3	Teflon	990058	990061
Gear	6	6	316 SS	990020	990016
Gear	6	8	Ryton	990022	990018
Gear	6	K	Kynar	990085	990666
Gear	6	P	PEEK	990023	990019
Key, Gear	24	1, 3, 6, 8, K, P	316 SS	990026	990026
Position 6 – Wear Plates					
Wear Plate, Relieved	7	3	Teflon	3120522 (4)	3120505 (4)
Wear Plate, Relieved	7	4	SiC	3120513 (4)	3120507 (4)
Wear Plate, Relieved	7	E	Carbon 60	3120524 (4)	3120504 (4)
Wear Plate, Relieved	7	P	PEEK	3120502 (8)	3120502 (4)
Position 7 – Bearings					
Bearing	3	3	Teflon	990065 (4)	990065 (4)
Bearing	3	B	SiC	990006 (4)	990006 (4)
Bearing	3	E	Carbon 60	990008 (4)	990008 (4)
Bearing	3	P	PEEK	990007 (4)	990007 (4)
Position 8 – Outer Magnet Bore / Motor Frame (Bracket, Adapter & Hardware)					
1-1/8" Bore – NEMA 182/184TC	–	5	–	See Position 14 for Outer Magnet	
1-3/8" Bore – NEMA 213/215TC	–	6	–		
1-5/8" Bore – NEMA 254/256TC	–	7	–		
28 mm Bore – IEC 100/112	–	8	–		
38 mm Bore – IEC 132	–	9	–		
Close-Coupled, MC (Additional Parts)	–	5 thru 9	–	See Appendix 4	
Position 9 – Bearing Flush Option (Front & Rear Housings)					
Front Housing, MC/CC, Std./EBF	8	0, 1	316 SS	S3120130	S3120130
Front Housing, MC/CC, IBF	8	2	316 SS	S3120132	S3120132
Rear Housing, Standard	2	0	316 SS	3120201	3120201
Rear Housing, EBF	2	1	316 SS	3120206	3120206
Rear Housing, IBF	2	2	316 SS	3120216	3120216
Plug, 1/8 NPT (Front Housing, Std./IBF)	9	0, 2	316 SS	362304 (1)	362304 (1)
Plug, 1/8 NPT (Front/Rear Housings/EBF)	9	1	316 SS	362304 (3)	362304 (3)
Position 10 – Shafts					
Drive Shaft, MC, Uncoated	20	0	316 SS	990004	990004
Drive Shaft, MC, CO-Coated	20	1	316 SS/CO	990004-CO	990004-CO
Drive Shaft, MC, TC-Coated	20	2	316 SS/TC	990004-TC	990004-TC
Idler Shaft, Uncoated	1	0	316 SS	990000	990000
Idler Shaft, CO-Coated	1	1	316 SS/CO	990000-CO	990000-CO
Idler Shaft, TC-Coated	1	2	316 SS/TC	990000-TC	990000-TC

See page 21 for Reference Drawing.

Liquiflo Chemical Processing Pumps™	H-Series Gear Pumps BOM: MAG-DRIVE, CC Models H12R & H12F
---	--

Part Description	Drwg. Item #	316 Stainless Steel Construction			
		Code	Material	H12R	H12F
Position 11 – O-Rings					
O-ring, Housing (2-047)	5	0	Teflon	3121101 (2)	3121101 (2)
O-ring, Containment Can (2-049)	19	0	Teflon	3121103	3121103
O-ring, Housing (2-047)	5	6	Silicone/FEP	3121123 (2)	3121123 (2)
O-ring, Containment Can (2-049)	19	6	Silicone/FEP	3121124	3121124
O-ring, Housing (2-047)	5	B	Buna-N	3121105 (2)	3121105 (2)
O-ring, Containment Can (2-049)	19	B	Buna-N	3121115	3121115
O-ring, Housing (2-047)	5	E	EPDM	3121110 (2)	3121110 (2)
O-ring, Containment Can (2-049)	19	E	EPDM	3121111	3121111
O-ring, Housing (2-047)	5	V	Viton	3121112 (2)	3121112 (2)
O-ring, Containment Can (2-049)	19	V	Viton	3121119	3121119
O-ring, Housing (2-047)	5	K	Kalrez	3121116 (2)	3121116 (2)
O-ring, Containment Can (2-049)	19	K	Kalrez	3121117	3121117
Position 12 – Retaining Rings					
Retaining Ring, Gear	4	0	316 SS	990024 (4)	990024 (4)
Retaining Ring, Inner Magnet	25	0	316 SS	S3146702	S3146702
Position 13 – Bearing Pins					
Pin, Bearing Lock	26	6	316 SS	3120801 (4)	3120801 (4)
Position 14 – Magnetic Coupling					
Inner Magnet, MCK – 7/8" Bore	11	K	316 SS/SmCo	SIMCK-07	SIMCK-07
Outer Magnet, MCK – 1-1/8" Bore	10	K (Pos. 8 = 5)	CS/SmCo	SOMCK-9-CC	SOMCK-9-CC
Outer Magnet, MCK – 1-3/8" Bore	10	K (Pos. 8 = 6)	CS/SmCo	SOMCK-11-CC	SOMCK-11-CC
Outer Magnet, MCK – 1-5/8" Bore	10	K (Pos. 8 = 7)	CS/SmCo	SOMCK-13-CC	SOMCK-13-CC
Outer Magnet, MCK – 28 mm Bore	10	K (Pos. 8 = 8)	CS/SmCo	SOMCK-112-CC	SOMCK-112-CC
Outer Magnet, MCK – 38 mm Bore	10	K (Pos. 8 = 9)	CS/SmCo	SOMCK-132-CC	SOMCK-132-CC
Inner Magnet, MCJ – 7/8" Bore	11	J	316 SS/SmCo	SIMCJ-07	SIMCJ-07
Outer Magnet, MCJ – 1-1/8" Bore	10	J (Pos. 8 = 5)	CS/SmCo	SOMCJ-9-CC	SOMCJ-9-CC
Outer Magnet, MCJ – 1-3/8" Bore	10	J (Pos. 8 = 6)	CS/SmCo	SOMCJ-11-CC	SOMCJ-11-CC
Outer Magnet, MCJ – 1-5/8" Bore	10	J (Pos. 8 = 7)	CS/SmCo	SOMCJ-13-CC	SOMCJ-13-CC
Outer Magnet, MCJ – 28 mm Bore	10	J (Pos. 8 = 8)	CS/SmCo	SOMCJ-112-CC	SOMCJ-112-CC
Outer Magnet, MCJ – 38 mm Bore	10	J (Pos. 8 = 9)	CS/SmCo	SOMCJ-132-CC	SOMCJ-132-CC
Key, Inner Magnet	13	K, J	316 SS	S3140079	S3140079
Position 15 – Containment Can					
Containment Can, Single Wall	12	S	316 SS	S3142004-CC	S3142004-CC
Dual Kan Option (Modified Parts)	12	D	316 SS	Consult Factory	
Suffix – Trim Options					
Temperature Trim (Gears & Bearings)	–	-8(T) ¹	–	Consult Factory	
Viscosity Trim (Gears)	–	-9D, -9T	–		

1 - T = Application Temperature in °F (e.g., -8(300) = Temperature Trim at 300°F).

Liquiflo Chemical Processing Pumps™	H-Series Gear Pumps BOM: MAG-DRIVE, CC Models H12R & H12F
---	--

Part Description	Drwg. Item #	Alloy-C Construction			
		Code	Material	H12R	H12F
Position 3 – Basic Material & Port Type (Center Housing, Alignment Pins & Hardware)					
Center Housing, NPT	21	H	Alloy-C	3120005	3120005
Center Housing, Flanged (ANSI 150# RF)	21	C	Alloy-C	3120007	3120007
Center Housing, BSPT	21	Y	Alloy-C	3120009	3120009
Pin, Housing Alignment	27	H, C, Y	Alloy-C	3120803 (4)	3120803 (4)
Bolt, Housing (5/16-18 x 1 HHCS)	14	H, C, Y	18-8 SS	3122004 (12)	3122004 (12)
Lockwasher, Housing (5/16)	15	H, C, Y	18-8 SS	3126341 (12)	3126341 (12)
Screw, C. Can (5/16-24 x 5/8 FH-SHCS)	18	H, C, Y	18-8 SS	S641109 (8)	S641109 (8)
Position 4 – Drive Gear					
Gear	22	1	Alloy-C	990021	990017
Gear	22	3	Teflon	990058	990061
Gear	22	6	316 SS	X	X
Gear	22	K	Kynar	990085	990666
Gear	22	P	PEEK	990023	990019
Key, Gear	23	1, 3, K, P	Alloy-C	990027	990027
Position 5 – Idler Gear					
Gear	6	1	Alloy-C	990021	990017
Gear	6	3	Teflon	990058	990061
Gear	6	6	316 SS	X	X
Gear	6	8	Ryton	990022	990018
Gear	6	K	Kynar	990085	990666
Gear	6	P	PEEK	990023	990019
Key, Gear	24	1, 3, 8, K, P	Alloy-C	990027	990027
Position 6 – Wear Plates					
Wear Plate, Relieved	7	3	Teflon	3120522 (4)	3120505 (4)
Wear Plate, Relieved	7	4	SiC	3120513 (4)	3120507 (4)
Wear Plate, Relieved	7	E	Carbon 60	3120524 (4)	3120504 (4)
Wear Plate, Relieved	7	P	PEEK	3120502 (8)	3120502 (4)
Position 7 – Bearings					
Bearing	3	3	Teflon	990065 (4)	990065 (4)
Bearing	3	B	SiC	990006 (4)	990006 (4)
Bearing	3	E	Carbon 60	990008 (4)	990008 (4)
Bearing	3	P	PEEK	990007 (4)	990007 (4)
Position 8 – Outer Magnet Bore / Motor Frame (Bracket, Adapter & Hardware)					
1-1/8" Bore – NEMA 182/184TC	–	5	–	See Position 14 for Outer Magnet	
1-3/8" Bore – NEMA 213/215TC	–	6	–		
1-5/8" Bore – NEMA 254/256TC	–	7	–		
28 mm Bore – IEC 100/112	–	8	–		
38 mm Bore – IEC 132	–	9	–		
Close-Coupled, MC (Additional Parts)	–	5 thru 9	–	See Appendix 4	
Position 9 – Bearing Flush Option (Front & Rear Housings)					
Front Housing, MC/CC, Std./EBF	8	0, 1	Alloy-C	S3120131	S3120131
Front Housing, MC/CC, IBF	8	2	Alloy-C	S3120133	S3120133
Rear Housing, Standard	2	0	Alloy-C	3120205	3120205
Rear Housing, EBF	2	1	Alloy-C	3120207	3120207
Rear Housing, IBF	2	2	Alloy-C	3120217	3120217
Plug, 1/8 NPT (Front Housing, Std./IBF)	9	0, 2	Alloy-C	362301 (1)	362301 (1)
Plug, 1/8 NPT (Front/Rear Housings/EBF)	9	1	Alloy-C	362301 (3)	362301 (3)
Position 10 – Shafts					
Drive Shaft, MC, Uncoated	20	0	Alloy-C	990005	990005
Drive Shaft, MC, CO-Coated	20	1	Alloy-C/CO	990005-CO	990005-CO
Drive Shaft, MC, TC-Coated	20	2	Alloy-C/TC	990005-TC	990005-TC
Idler Shaft, Uncoated	1	0	Alloy-C	990001	990001
Idler Shaft, CO-Coated	1	1	Alloy-C/CO	990001-CO	990001-CO
Idler Shaft, TC-Coated	1	2	Alloy-C/TC	990001-TC	990001-TC

See page 21 for Reference Drawing.

Liquiflo Chemical Processing Pumps™	H-Series Gear Pumps BOM: MAG-DRIVE, CC Models H12R & H12F
---	--

Part Description	Drwg. Item #	Alloy-C Construction			
		Code	Material	H12R	H12F
Position 11 – O-Rings					
O-ring, Housing (2-047)	5	0	Teflon	3121101 (2)	3121101 (2)
O-ring, Containment Can (2-049)	19	0	Teflon	3121103	3121103
O-ring, Housing (2-047)	5	6	Silicone/FEP	3121123 (2)	3121123 (2)
O-ring, Containment Can (2-049)	19	6	Silicone/FEP	3121124	3121124
O-ring, Housing (2-047)	5	B	Buna-N	3121105 (2)	3121105 (2)
O-ring, Containment Can (2-049)	19	B	Buna-N	3121115	3121115
O-ring, Housing (2-047)	5	E	EPDM	3121110 (2)	3121110 (2)
O-ring, Containment Can (2-049)	19	E	EPDM	3121111	3121111
O-ring, Housing (2-047)	5	V	Viton	3121112 (2)	3121112 (2)
O-ring, Containment Can (2-049)	19	V	Viton	3121119	3121119
O-ring, Housing (2-047)	5	K	Kalrez	3121116 (2)	3121116 (2)
O-ring, Containment Can (2-049)	19	K	Kalrez	3121117	3121117
Position 12 – Retaining Rings					
Retaining Ring, Gear	4	0	Alloy-C	990025 (4)	990025 (4)
Retaining Ring, Inner Magnet	25	0	Alloy-C	S3146709	S3146709
Position 13 – Bearing Pins					
Pin, Bearing Lock	26	1	Alloy-C	3120803 (4)	3120803 (4)
Position 14 – Magnetic Coupling					
Inner Magnet, MCK – 7/8" Bore	11	K	Alloy-C/SmCo	SIMCK-17	SIMCK-17
Outer Magnet, MCK – 1-1/8" Bore	10	K (Pos. 8 = 5)	CS/SmCo	SOMCK-9-CC	SOMCK-9-CC
Outer Magnet, MCK – 1-3/8" Bore	10	K (Pos. 8 = 6)	CS/SmCo	SOMCK-11-CC	SOMCK-11-CC
Outer Magnet, MCK – 1-5/8" Bore	10	K (Pos. 8 = 7)	CS/SmCo	SOMCK-13-CC	SOMCK-13-CC
Outer Magnet, MCK – 28 mm Bore	10	K (Pos. 8 = 8)	CS/SmCo	SOMCK-112-CC	SOMCK-112-CC
Outer Magnet, MCK – 38 mm Bore	10	K (Pos. 8 = 9)	CS/SmCo	SOMCK-132-CC	SOMCK-132-CC
Inner Magnet, MCJ – 7/8" Bore	11	J	Alloy-C/SmCo	SIMCJ-17	SIMCJ-17
Outer Magnet, MCJ – 1-1/8" Bore	10	J (Pos. 8 = 5)	CS/SmCo	SOMCJ-9-CC	SOMCJ-9-CC
Outer Magnet, MCJ – 1-3/8" Bore	10	J (Pos. 8 = 6)	CS/SmCo	SOMCJ-11-CC	SOMCJ-11-CC
Outer Magnet, MCJ – 1-5/8" Bore	10	J (Pos. 8 = 7)	CS/SmCo	SOMCJ-13-CC	SOMCJ-13-CC
Outer Magnet, MCJ – 28 mm Bore	10	J (Pos. 8 = 8)	CS/SmCo	SOMCJ-112-CC	SOMCJ-112-CC
Outer Magnet, MCJ – 38 mm Bore	10	J (Pos. 8 = 9)	CS/SmCo	SOMCJ-132-CC	SOMCJ-132-CC
Key, Inner Magnet	13	K, J	Alloy-C	S3140080	S3140080
Position 15 – Containment Can					
Containment Can, Single Wall	12	S	Alloy-C	S3142003-CC	S3142003-CC
Dual Kan Option (Modified Parts)	-	D	Alloy-C	Consult Factory	
Suffix – Trim Options					
Temperature Trim (Gears & Bearings)	-	-8(T) ¹	-	Consult Factory	
Viscosity Trim (Gears)	-	-9D, -9T	-		

1 - T = Application Temperature in °F (e.g., -8(300) = Temperature Trim at 300°F).

Appendix 1: Exploded View Reference Drawings

Models H12R & H12F – SEALED, Long-Coupled

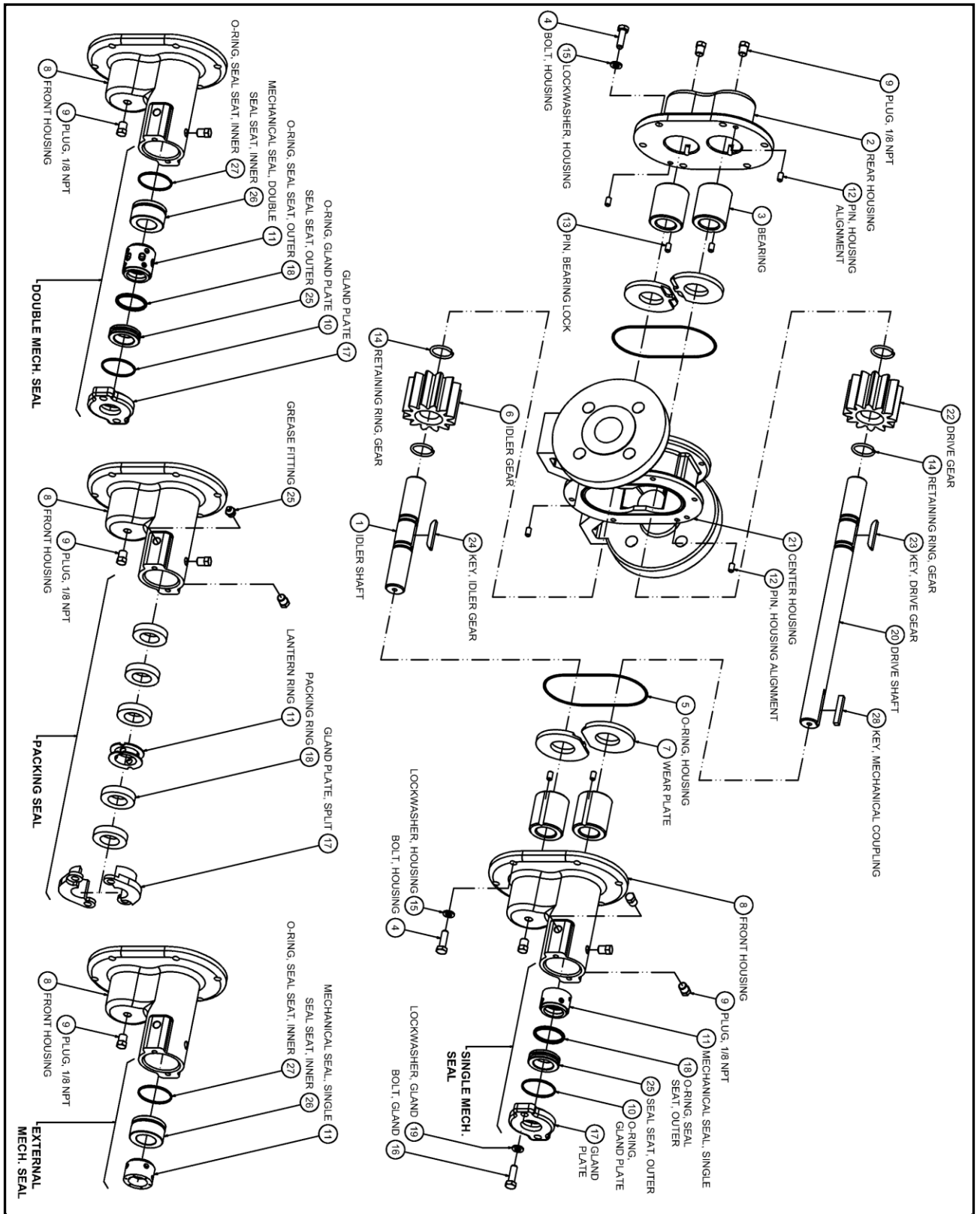

Appendix 1: Exploded View Reference Drawings (continued)

Models H12R & H12F – SEALED, Close-Coupled

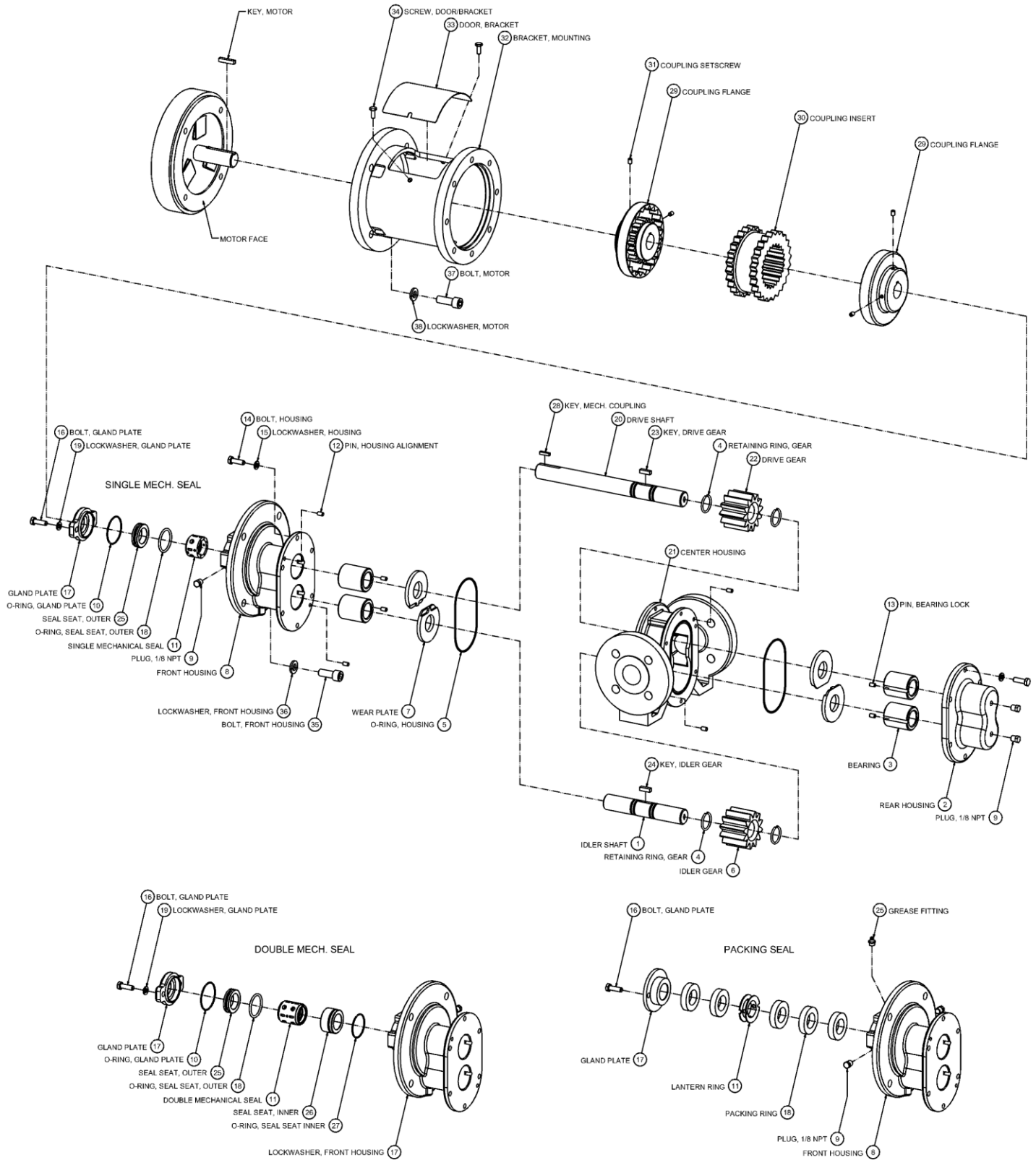

Appendix 1: Exploded View Reference Drawings (continued)

Models H12R & H12F – MAG-DRIVE, Close-Coupled

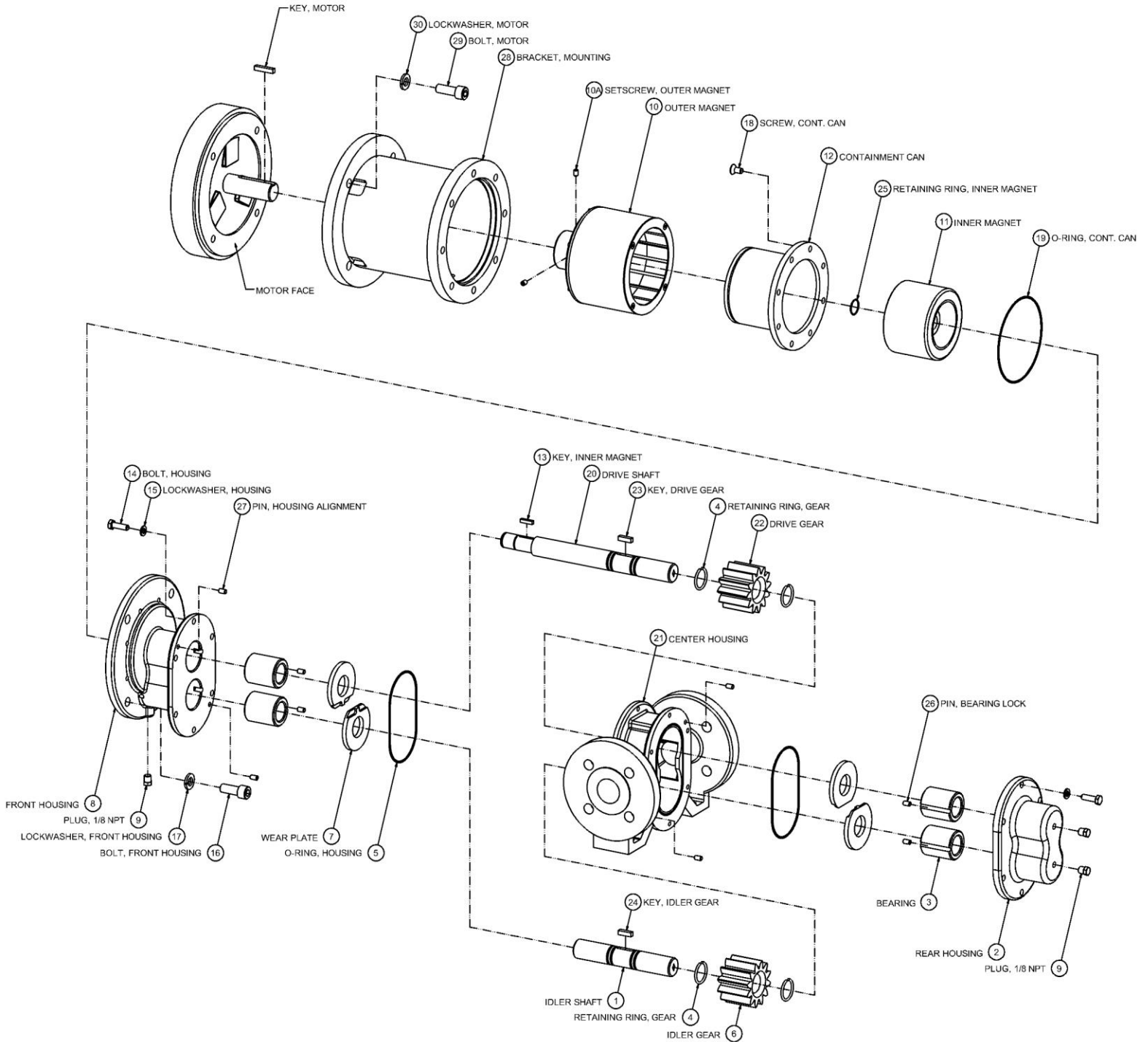

Appendix 2: Meaning of Abbreviated Terms

Term	Meaning	Notes
ANSI	American National Standards Institute	e.g., ANSI 150# flanges
BSPT	British Standard Pipe Threads	Type of threaded port
Buna-N	Buna Nitrile (rubber)	O-ring material; NBR; elastomer
C. Can	Containment Can	Part of Mag-drive pump
CC	Close-Coupled	Method of pump-motor coupling
CI	Cast Iron	Mechanical coupling flange structural material
CO	Chrome Oxide	Shaft coating material
CS	Carbon Steel	Bracket, adapter plate, mechanical coupling key and outer magnet structural material
DMS	Double Mechanical Seal	Internally mounted double seal
Drwg.	Drawing (Item #)	See corresponding exploded view reference drawing
EBF	External Bearing Flush	Housing option for H-Series pumps
EPDM	Ethylene-Propylene-Diene Monomer (rubber)	Mechanical coupling insert and O-ring material; elastomer
FH-SHCS	Flat Head, Socket Head Cap Screw	Type of bolt
HHCS	Hex Head Cap Screw	Type of bolt
HY	High-Yield (key)	Type of gear key
IBF	Internal Bearing Flush	Housing option for H-Series pumps
LC	Long-Coupled	Method of pump-motor coupling
LY	Low-Yield (key)	Type of gear key
MC	Magnetically Coupled	Mag-drive pump
MS	Mechanical Seal	Includes single & double seals
NPT	National Pipe Threads	Type of threaded port
PEEK	Poly-Ether-Ether-Ketone (plastic)	Bearing Grade PEEK; material option for gears, bearings & wear plates
Pos.	Position (#)	Position number of model code
PS	Packing Seal	Comprised of Teflon or Graphoil packing rings
RF	Raised Face	Type of flange
SHCS	Socket Head Cap Screw	Type of bolt
SiC	Silicon Carbide	Bearing, wear plate and seal seat material
Silicone/FEP	Silicone Rubber (encapsulated with) Fluoro-ethylene-propylene (plastic)	O-ring material; suggested for temperature cycling applications
SmCo	Samarium Cobalt	Inner and outer magnet material
SMS	Single Mechanical Seal	Internally mounted single seal
SS	Stainless Steel	e.g., 303 SS, 316 SS, 18-8 SS
Std.	Standard	Standard housing (without Flush)
TC	Tungsten Carbide	Shaft coating material
X	Not Available or Not Applicable	Used in lieu of Part Number
#	Number or Pound	e.g., Position #, Part #, 150# flanges, etc.

Appendix 3: Additional Parts for SEALED-CC Configuration

Mechanical Coupling, Bracket & Adapter

Model Code Pos. 14	Motor Frame	Mechanical Coupling ¹				Bracket ³		Adapter ⁴
		Part #	Size	Type (Woods)	Max Torque ²	Part # SMS/PS	Part # DMS	Part #
5	NEMA 182/184TC	A-5308	1-1/8" x 1-1/8"	6J	585	3120135	3120136	X
6	NEMA 213/215TC	A-5309	1-1/8" x 1-3/8"	6J	585	3120135	3120136	X
7	NEMA 254/256TC	A-5400	1-1/8" x 1-5/8"	7S	940	3120135	3120136	SP0047
8	IEC 100/112 – B5	A-5233	1-1/8" x 28 mm	6J	585	3120138	3120139	X
9	IEC 132 – B5	A-5317	1-1/8" x 38 mm	6J	585	3120138	3120139	SP0050

1 – Coupling material is Cast Iron flanges with EPDM insert. Coupling Temperature Range is -30°F to 275°F.

2 – Maximum Torque rating in inch-pounds at 75°F (24°C). Consult factory for couplings with higher torque ratings.

3 – Material is Cast Iron/Epoxy. Bracket includes 303 SS door (Part # 3120134) and two 1/4-20 x 5/8 bolts (Part # 620008).

4 – Material is Anodized Aluminum.

Assembly Hardware

Model Code Pos. 14	Part Description	Material	Size	Bolt Type	Part #	Qty.
5 thru 9	Bolt, Front Housing	18-8 SS	1/2-13 x 1-1/4	SHCS	3122010	4
	Lockwasher, Front Housing	18-8 SS	1/2	–	641107	4
5, 6	Bolt, Motor	18-8 SS	1/2-13 x 1-1/2	SHCS	641106	4
	Lockwasher, Motor	18-8 SS	1/2	–	641107	4
7	Bolt, Motor ¹	18-8 SS	1/2-13 x 2-3/4	SHCS	3122021	4
	Lockwasher, Motor ¹	18-8 SS	1/2	–	641107	4
8	Bolt, Motor	18-8 SS	1/2-13 x 2	SHCS	3122020	4
	Nut, Motor	18-8 SS	1/2-13	–	641108	4
	Lockwasher, Motor	18-8 SS	1/2	–	641107	4
9	Bolt, Motor	18-8 SS	1/2-13 x 1-1/4	SHCS	3122010	4
	Lockwasher, Motor	18-8 SS	1/2	–	641107	4
	Bolt, Adapter ²	18-8 SS	1/2-13 x 1-1/2	SHCS	641106	4
	Nut, Adapter ²	18-8 SS	1/2-13	–	641108	4
	Lockwasher, Adapter ²	18-8 SS	1/2	–	641107	4

1 – Also used to mount adapter plate (Part # SP0047) to motor.

2 – For mounting adapter plate (Part # SP0050) to motor.

Appendix 4: Additional Parts for MAG-DRIVE-CC Configuration

Bracket & Adapter

Model Code Pos. 8	Motor Frame	Bracket	Material	Adapter	Material
		Part #		Part #	
5	NEMA 182/184TC	3120133	Carbon Steel/ Epoxy	X	X
6	NEMA 213/215TC	3120133		X	X
7	NEMA 254/256TC	3120133		SP0047	Aluminum, Anodized
8	IEC 100/112 – B5 Flange	3120137		X	X
9	IEC 132 – B5 Flange	3120137		SP0050	Aluminum, Anodized

Assembly Hardware

Model Code Pos. 8	Part Description	Material	Size	Bolt Type	Part #	Qty.
5 thru 9	Bolt, Front Housing	18-8 SS	1/2-13 x 1-1/4	SHCS	3122010	4
	Lockwasher, Front Housing	18-8 SS	1/2	–	641107	4
5, 6	Bolt, Motor	18-8 SS	1/2-13 x 1-1/2	SHCS	641106	4
	Lockwasher, Motor	18-8 SS	1/2	–	641107	4
7	Bolt, Motor ¹	18-8 SS	1/2-13 x 2-3/4	SHCS	3122021	4
	Lockwasher, Motor ¹	18-8 SS	1/2	–	641107	4
8	Bolt, Motor	18-8 SS	1/2-13 x 2	SHCS	3122020	4
	Nut, Motor	18-8 SS	1/2-13	–	641108	4
	Lockwasher, Motor	18-8 SS	1/2	–	641107	4
9	Bolt, Motor	18-8 SS	1/2-13 x 1-1/4	SHCS	3122010	4
	Lockwasher, Motor	18-8 SS	1/2	–	641107	4
	Bolt, Adapter ²	18-8 SS	1/2-13 x 1-1/2	SHCS	641106	4
	Nut, Adapter ²	18-8 SS	1/2-13	–	641108	4
	Lockwasher, Adapter ²	18-8 SS	1/2	–	641107	4

¹ – Also used to mount adapter plate (Part # SP0047) to motor.

² – For mounting adapter plate (Part # SP0050) to motor.