

SERIES	MODEL	CONFIGURATION	SEAL TYPE
H-Series 3-Series	H1F or H3F 31F or 33F	Sealed Gear Pump Long-Coupled Base-Mounted Version with RF Flanges.	Single Mechanical Seal, Double Mechanical Seal or Packing

UNITS: inches [mm]

SEAL TYPE	"A"	"B"	"C"
Single or Double Mechanical Seal	1.12 [28.4]	5.44 [138.2]	6.94 [176.3]
Packing	1.19 [30.2]	5.44 [138.2]	6.94 [176.3]

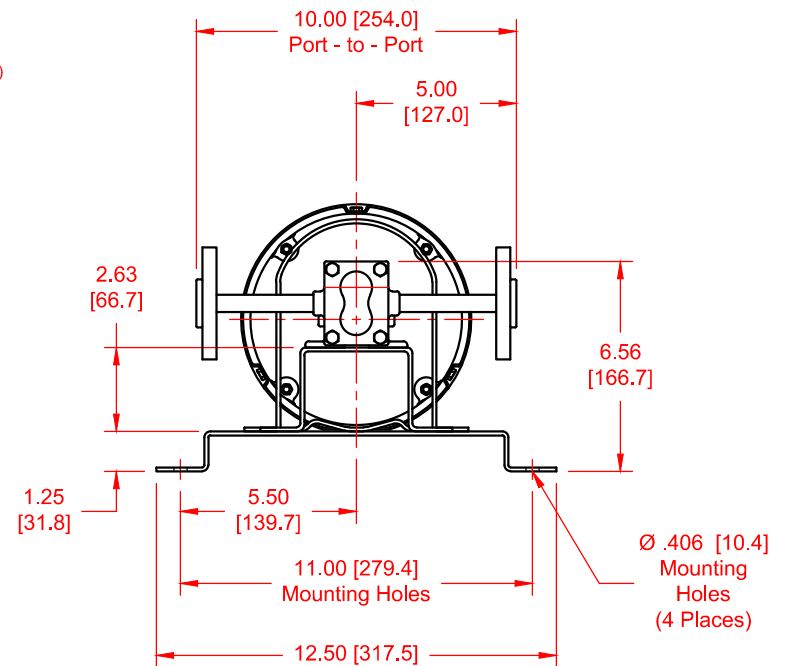
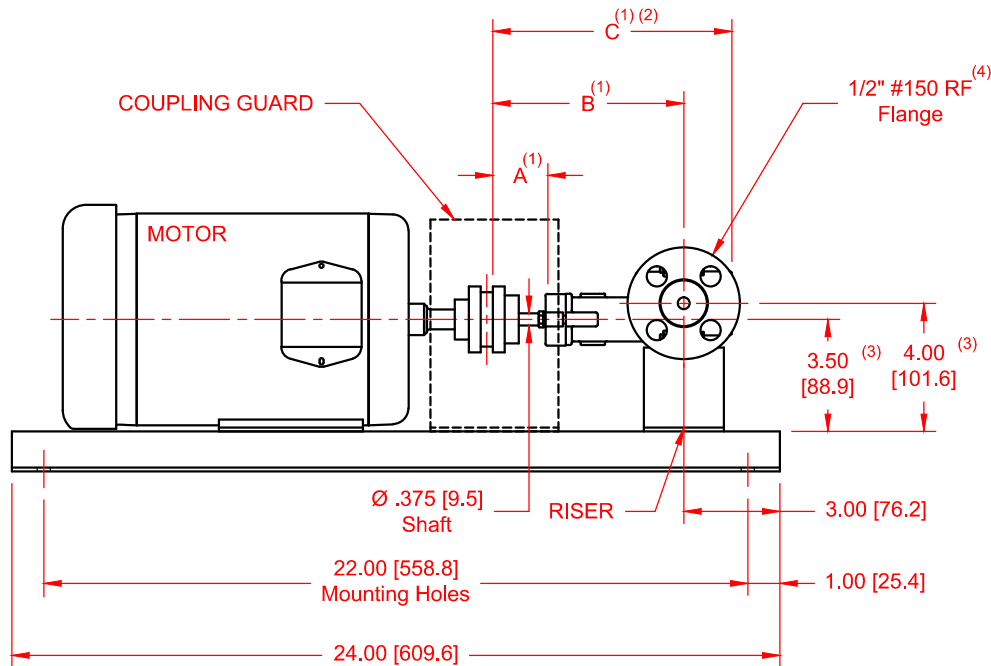

NOTES:

- 1) Dimension to end of pump shaft.
- 2) Dimension to end of pump rear housing.
- 3) Applies for NEMA 56, 143T & 145T Motors.
- 4) Also available with ANSI 1/2" #300 RF and DN10 PN 16 flanges.