

SERIES	MODEL	CONFIGURATION	SEAL TYPE
H-Series 3-Series	H14F 314F	Sealed Gear Pump, Long-Coupled Base-Mounted Version with NPT or BSPT Ports	Single Mechanical Seal, Double Mechanical Seal or Packing

UNITS: inches [mm]

SEAL TYPE	314F Shaft Ø1.000		H14F Shaft Ø1.125	
	"A"	"B"	"A"	"B"
Single or Double Mechanical Seal	14.75 [374.7]	19.69 [500.1]	9.95 [252.7]	14.89 [378.2]
Packing	14.75 [374.7]	19.69 [500.1]	9.95 [252.7]	14.89 [378.2]

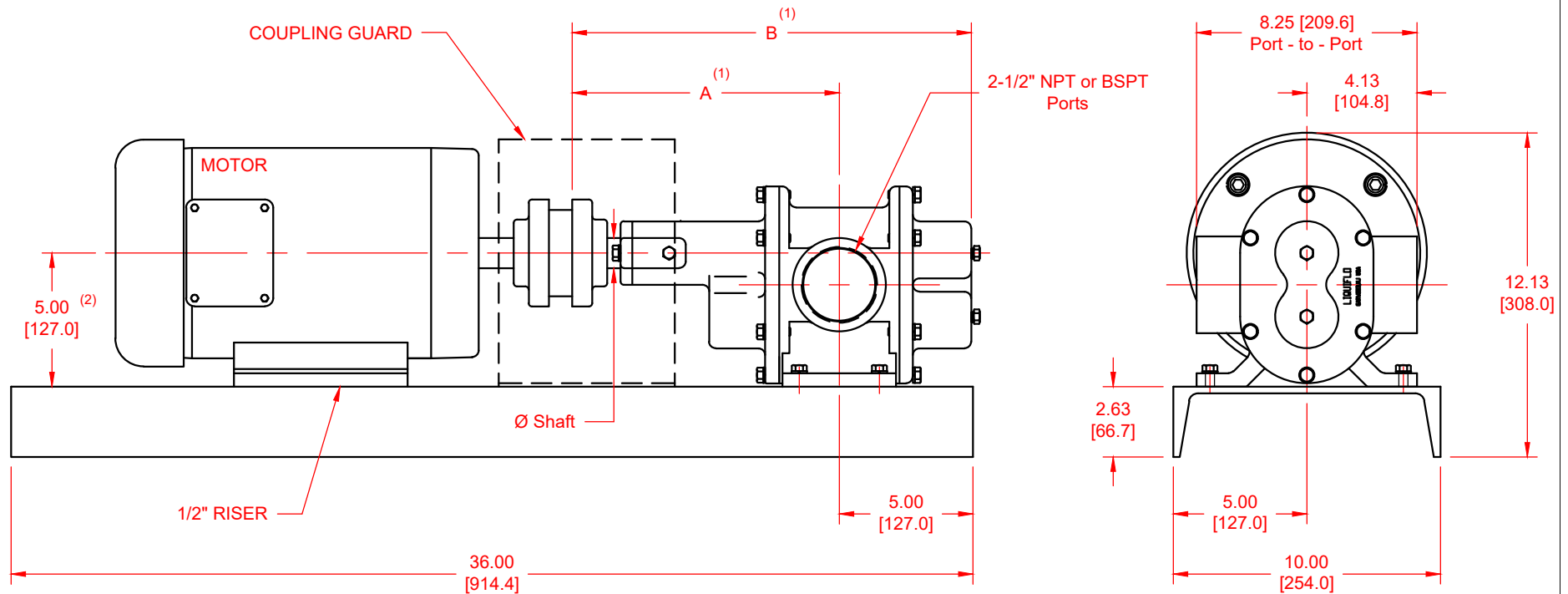

- NOTES:
 1) Dimension to end of pump shaft.
 2) Applies for NEMA 182/184TC motor.