

SERIES	MODEL	CONFIGURATION	SEAL TYPE
H-Series 3-Series	H14F 314F	Mag-Drive Gear Pump, Long-Coupled Base-Mounted Version with ANSI RF Flanges	Mag-Drive (Sealless)

UNITS: inches [mm]

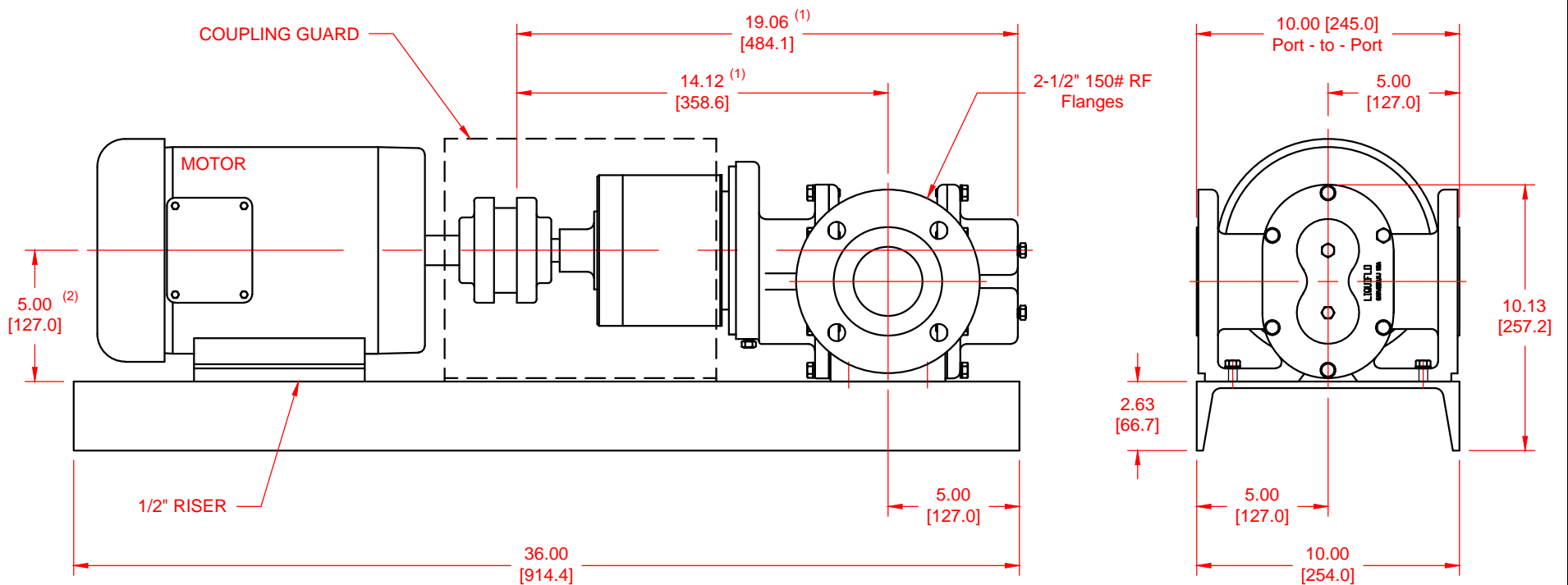

NOTES:
 1) Dimension to end of pump shaft.
 2) Applies for NEMA 182/184TC motor.