

SERIES	MODEL	CONFIGURATION	SEAL TYPE
H-Series	H14F	Sealed or Mag-Drive Gear Pump Close-Coupled Base-Mounted Version with NPT or BSPT Ports	Single or Double Mechanical Seal or Mag-Drive (Sealless)

UNITS: inches [mm]

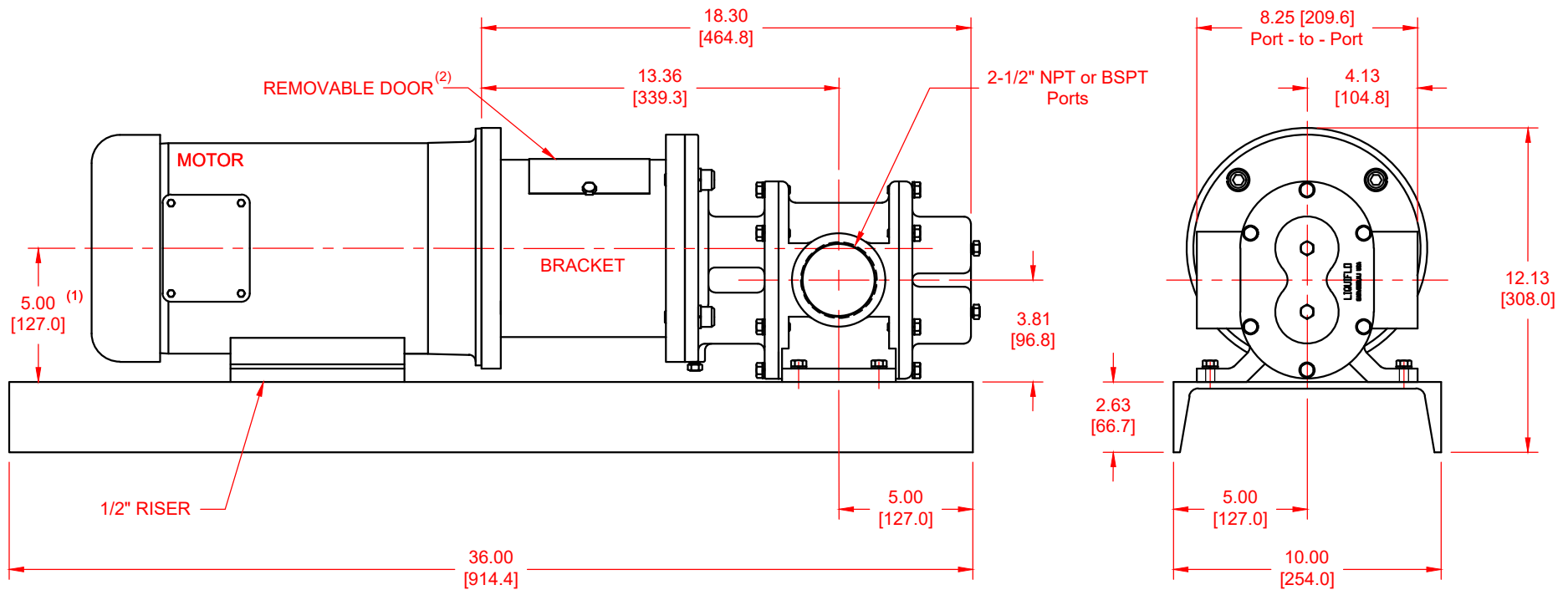

NOTES:

- 1) Applies for NEMA 182/184TC motor.
- 2) Enables access to mechanical coupling; not applicable for Mag-drive pumps.