

| SERIES | GROUP | MODEL | CONFIGURATION |
|--------|-------|---------------------------------------|---|
| ENDURA | II | AB 3 x 2 x 8 w/ Group 1 Drive Section | ANSI Centrifugal Pump Mag-Drive, Long-Coupled Version w/ Power Frame |

UNITS: inches

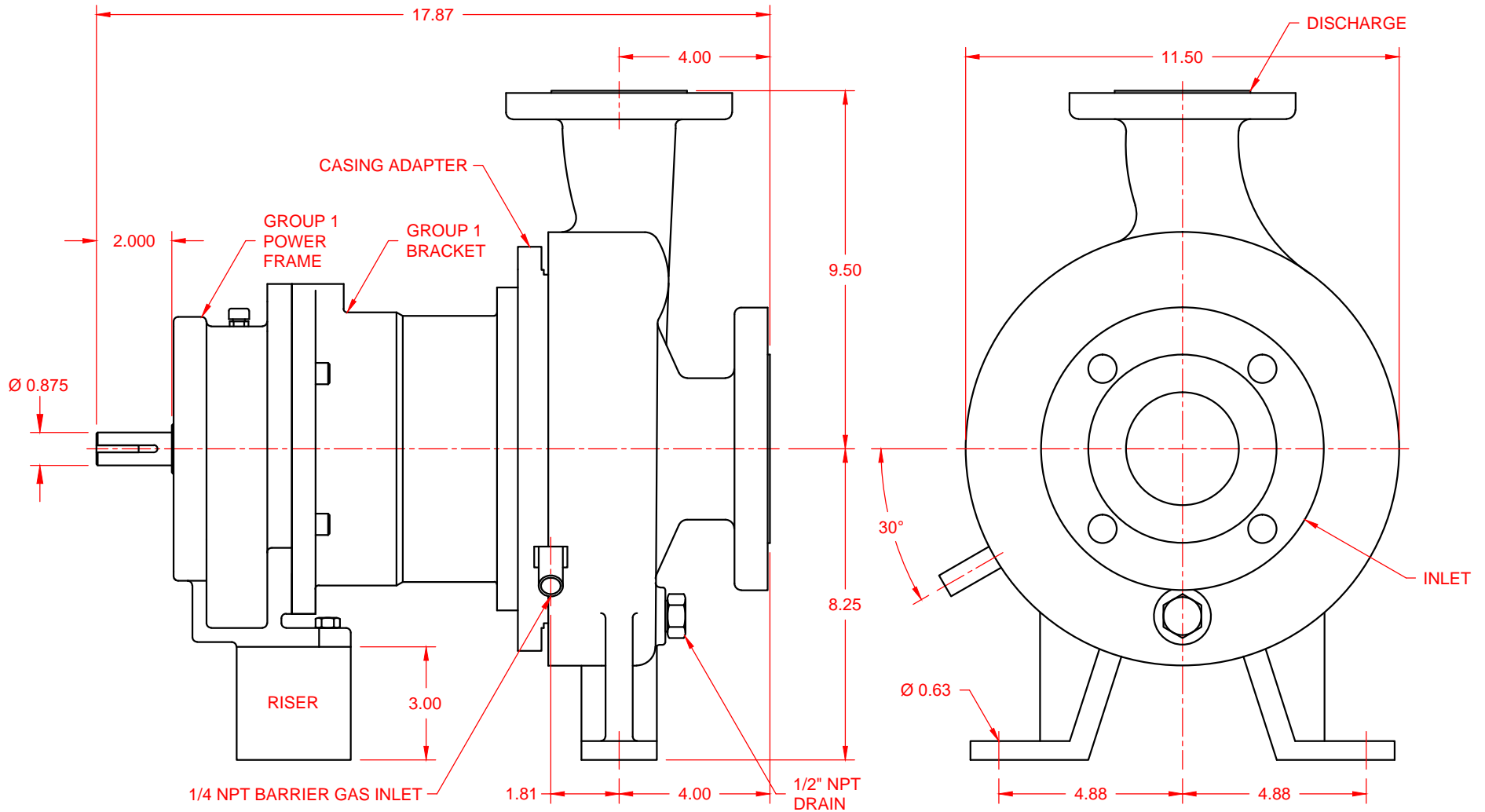

| CASING SIZE | INLET | DISCHARGE |
|-------------|-------|-----------|
| 3 x 2 x 8 | 3" RF | 2" RF |

NOTES:
 1) Foot Mount Motor is required.

DWG. NO. 20843 REV.